



**LaACES
Student
Ballooning
Course**

Lecture 09.01: Data Acquisition



Sensors and Transducers

A **transducer** is a material, substance, or device that converts a signal from one form of energy into another.

A **sensor** is a transducer that detects or measures a physical property and records, indicates, or otherwise responds to it.

We are primarily concerned with sensors that will react to some physical property, for example pressure, and convert to an electrical signal.



NOTE: Transducers

There are certain sensors types of sensors that commonly referred to as transducers.

Often these are associated with sensors for measuring pressure, liquid levels, and ultrasonics.

However, it should be pointed out that all sensors are transducers even if they are not explicitly called a transducer.



Ultrasound Transducer



Pressure Transducer



Sensor Classification

A **passive sensor** detects or responds to external stimuli from the environment

– **Ex. Bulb Thermometer**

An **active sensor** emits a signal (light, sound, radio wave) and detects reflections or the environment's reaction to the emitted signal

– **Ex. Radar**

Passive Sensor

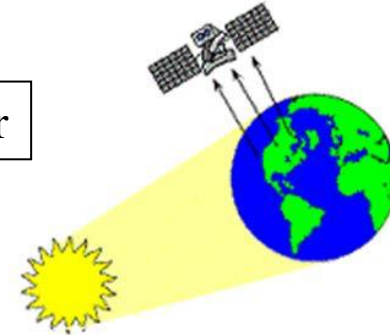

Active sensor

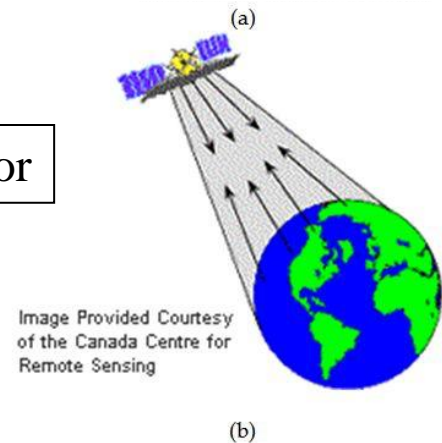



Example Sensor Inputs: Physical Variables

- Temperature
- Pressure
- Humidity
- Light Intensity
- Radioactivity
- Acceleration
- Altitude
- EMF strength
 - (Electromagnetic fields)

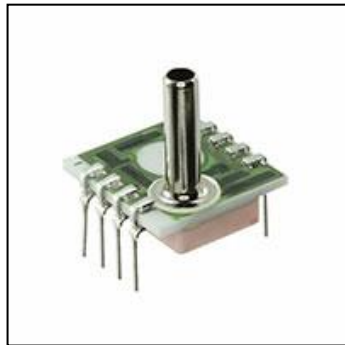

Pressure Sensor

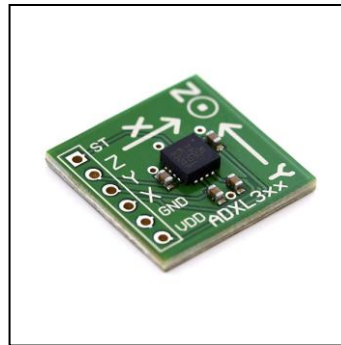

Accelerometer

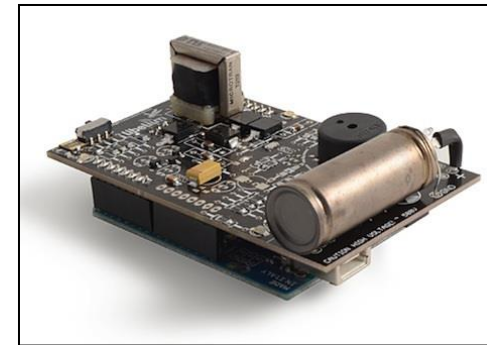

Geiger Counter



Electrical Signal Outputs

The output of a sensor will vary depending on the sensor in use. Could be electrical, mechanical, sound etc. Most of the sensors we will use will output electrical signals.

These signals can vary in:

- Voltage (Most common final output)
- Current
- Variation with time
 - Pulse Amplitude & Width
 - Frequency
 - Signal Duration

Some sensors will include ADCs and output a digital signal that must be interpreted by another device such as a microcontroller or computer.



Temperature Sensors



IN457 Si Diode

There are a multitude of methods to measure temperature. It can be measured by thermistors (resistance varies with temperature), thermocouples (dissimilar metals create a voltage varies with temperature), or semiconductor junction devices (voltage across junction varies with temperature).

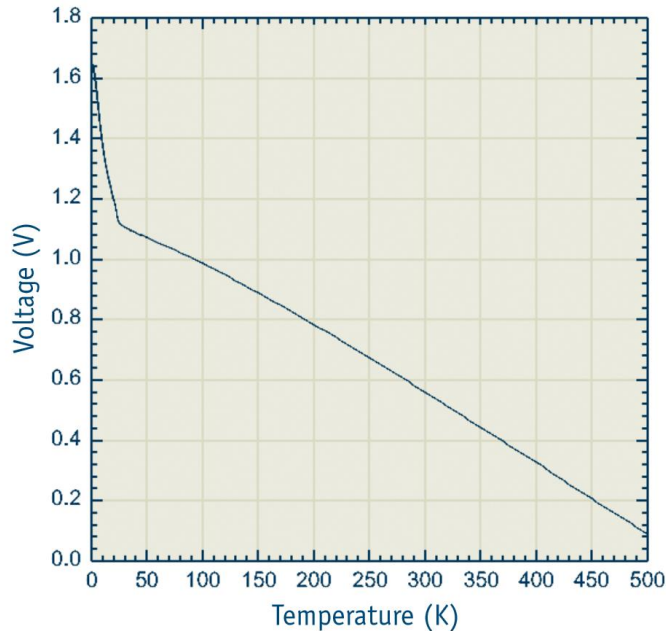

PN-junction diodes can be used to measure temperatures in the range of 20 – 500K. In this range, the forward voltage of the diode varies linearly with temperature. The forward voltage drops approximately $-2.1 \text{ mV} / \text{K}$.



Pressure Sensors

A *diaphragm* bows in or out depending on the atmospheric pressure being applied to it. The diaphragm is made of conductive material. This changes the distance and conductivity between it and a metal plate beneath it. A transducer reads this change in conductance as pressure. Note, temperature compensation is essential for proper pressure readings.

The MegaSat uses a pressure transducer that gauges *absolute* pressure (zero reading = perfect vacuum). It also has temperature compensation built in.



1230-015A-3L Pressure
Transducer



Humidity Sensors

How they work

The most common way humidity sensors work is by gauging how electricity jumps the air gap in a capacitor. All substances conduct electricity differently, and this includes dry vs humid air. The change in conductivity is interpreted as humidity.

MegaSat

The board uses a capacitive sensing element that is light sensitive so care must be taking to keep it out of the light.



HIH-4000-003
Humidity Sensor



Acceleration and Orientation Sensors

There are multiple ways to make an accelerometer. The MegaSat has the simplest type. A semiflexible conductive mass spans a gap between two beams like a bridge. Underneath it lies a conductive plate. If an accelerative force causes the bridge to bend, then the capacitance between it and the plate will change. Circuitry converts this change to voltage for an acceleration reading.

A gyroscope is more complicated. The physics involved includes the conservation of angular momentum and the *Coriolis Effect*. The gyro used by the MegaSat gets its readings from the change in capacitance caused by the Coriolis Effect. Curious students may research “*vibratory MEMS rate gyroscope*” if they would like to know more.



SEN-11028 ROHS
Accelerometer-Gyro
combo



Signal Conditioning

Sensors output an electric signal, but many times the signal cannot be directly interpreted by humans or other electronics. This can be fixed with signal conditioning.

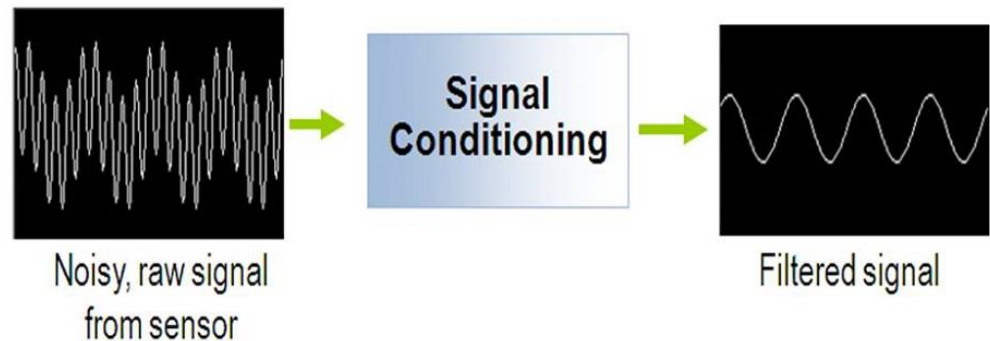
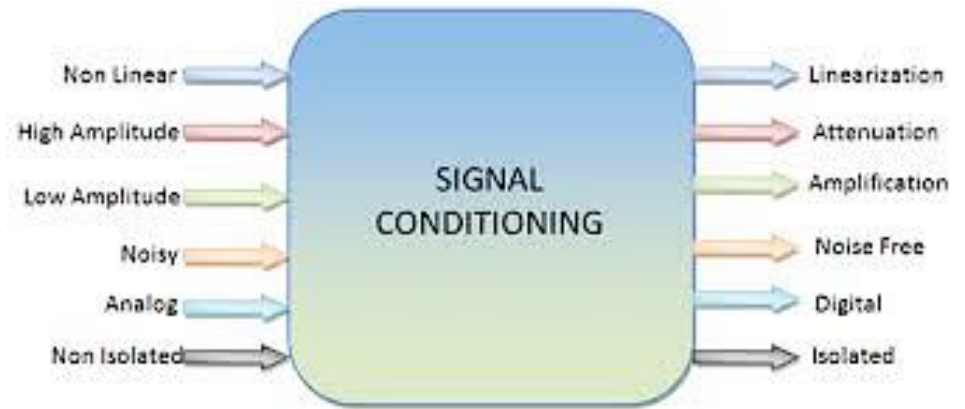



Span and Base

Span refers to the voltage *range* of possible outputs of the device.

Base refers to the lowest possible output of the device.

We want to use signal conditioning to match the span and base of our sensor to device reading it.

If they do not match than the some of information in the signal could be lost.

Example:

Temperature sensor:

450 mV to 800 mV

BASE = 450 mV, ***SPAN*** = 350 mV

Signal Conditioning Output:

0V to 3V (to match ADC)

BASE = 0V, ***SPAN*** = 3V



Span and Base Adjustment

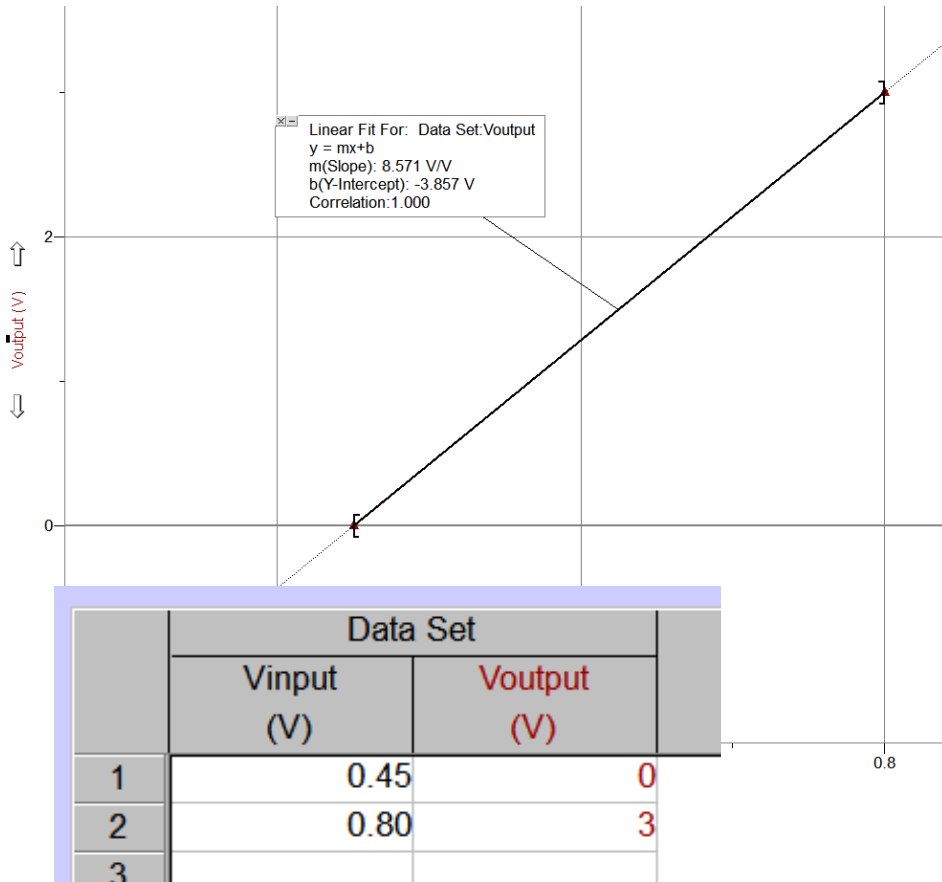

The relation between the input and desired output is simply a line passing through the two points formed by minimum and maximum values.

The input values on x axis and output values on the y.

In this case the line that passes through (0.45,0) and (0.80, 3)



Transfer Function

The equation of between the input and the output of the signal condition is called the **transfer function**.

For a linear transfer function call the slope the **gain** and the intercept the **offset**.

$$\text{Gain} = 8.571$$

$$\text{Offset} = -3.857 \text{ V}$$

How do we design and build a circuit that performs this transfer function?

Amplifying Circuits

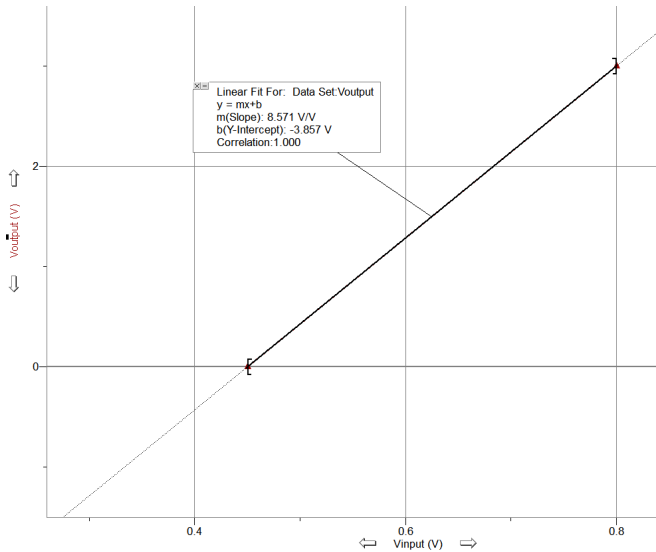



Amplification and Attenuation

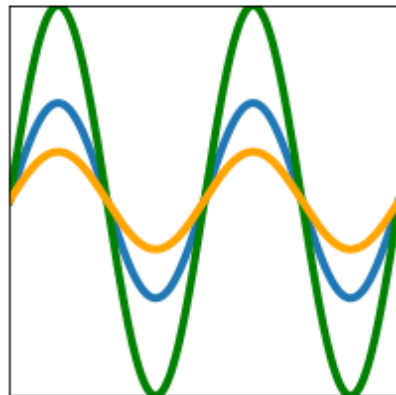
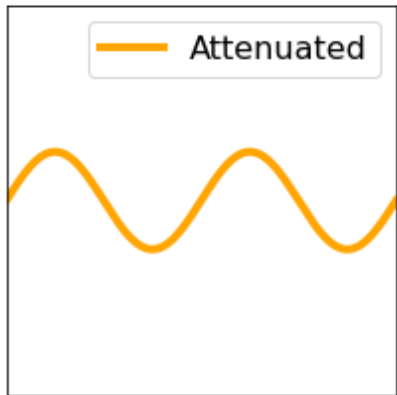
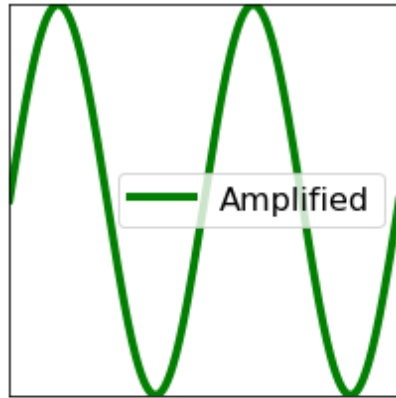
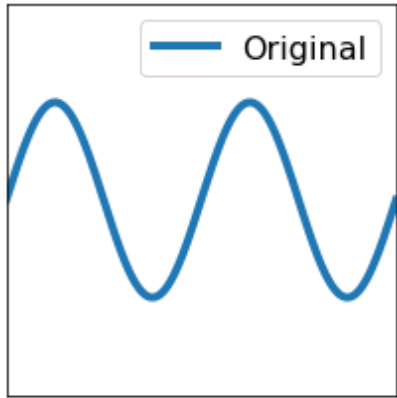

When a signal is too small to be interpreted correctly, the signal can be amplified. **Amplification** is the process of increasing the power of an electrical signal. (Gain >1)

Sometimes, a signal is strong enough to damage equipment or other devices or exceed the desired thresholds. In such cases, it is often useful to attenuate the signal. **Attenuation** is the process of reducing the power of an electrical signal. (Gain <1) Attenuation can occur when a signal is sent over long distances.



Signal Conditioning Circuit

Operational Amplifier or “Op amp”

Amplifying circuits are built using an IC called an op amp.

An op amp takes 2 input signals and outputs 1.

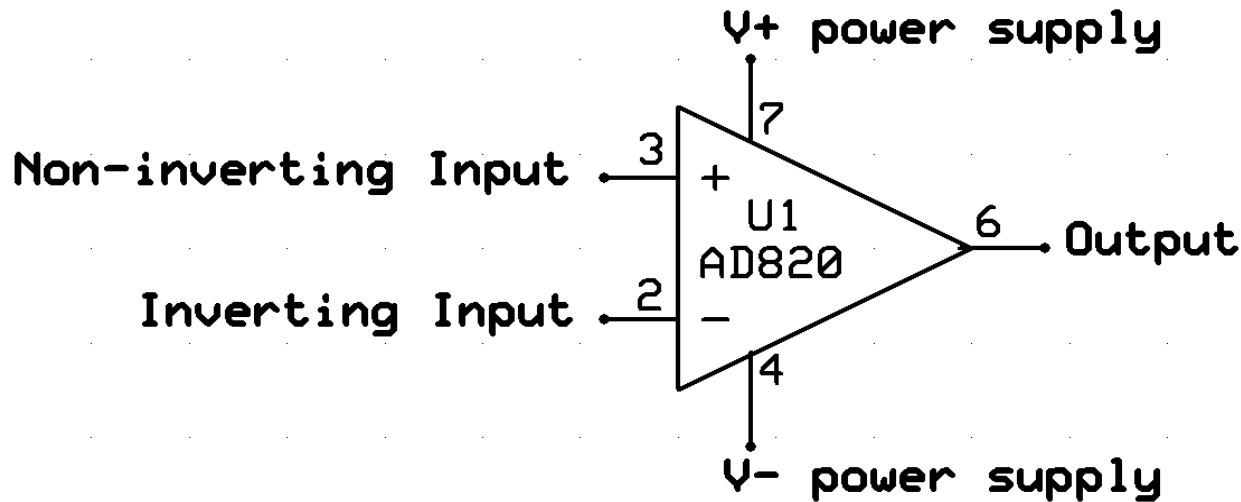



Operational Amplifier ICs

Available in Single(1x), Dual(2x), Quad(4x) Packages
May be Bipolar power supply (ex. $\pm V_s = \pm 12V$)
Single supply operation (ex. +12V, GND)
Variety of voltage and frequency ranges for different chips.

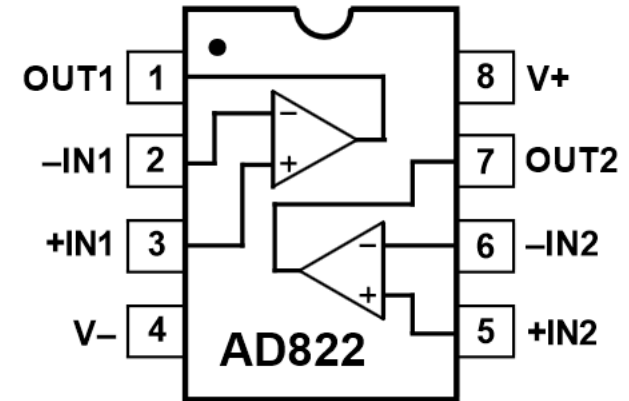
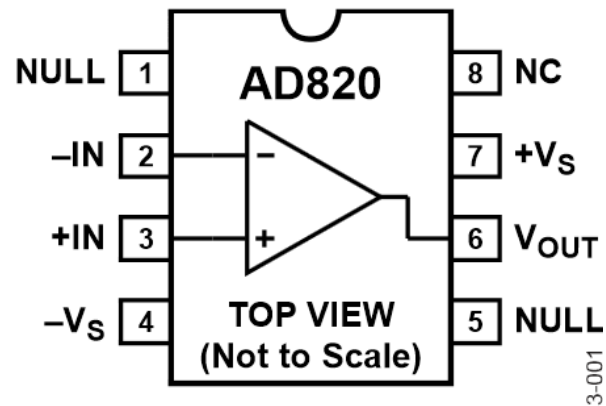
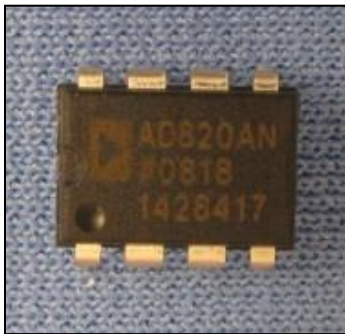



Op Amp Golden Rules

The output influences the input pins via the external **feedback** resistor. Use the **Rules** and **Ohm's Law** to analyze or synthesize op amp circuits.

Some common simple amplifying circuits are

- I. The output changes to do whatever is necessary to make the voltage difference between both inputs zero.**

- II. The inputs draw no current.**



Signal Conditioning Circuit

Buffer

A buffer provides voltage or current isolation between to components to prevent the signal from affecting the performance of a component.

Current on V_{out} comes from the supply, not V_{in} .

Gain of Buffer
 $V_{in} = V_{out}$
Gain=1

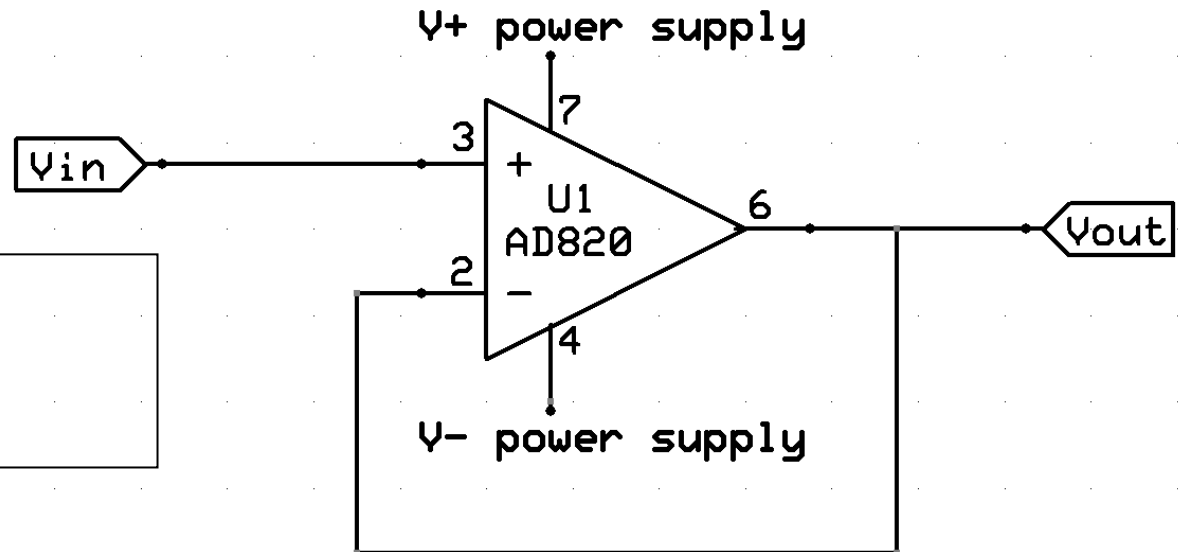



Signal Conditioning Circuit

Inverting Amplifier

Inverted op amps have V_{in} connected to the negative terminal.

Signal is inverted (flipped).

$$V_{out} = -V_{in} \left[\frac{R_{fb}}{R_{in}} \right]$$

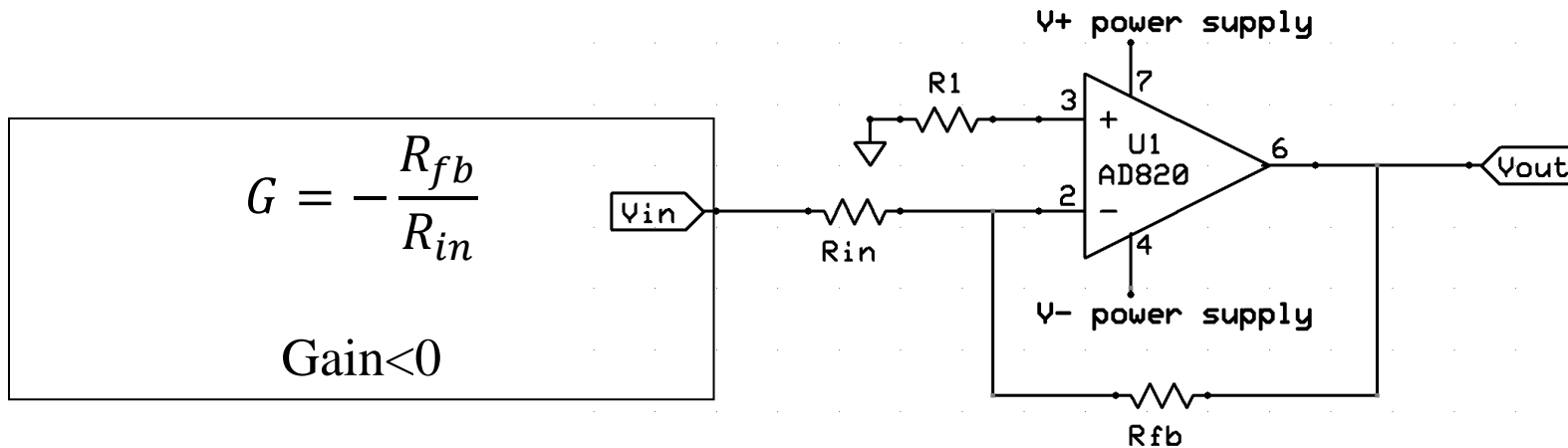



Signal Conditioning Circuit

Non-Inverting Amplifier

Non-inverted op amps have V_{in} connected to the positive terminal.
This is commonly used in electronics to isolated circuits from each other.

$$V_{out} = V_{in} \left[1 + \frac{R_{fb}}{R_{in}} \right]$$

$$G = 1 + \frac{R_{fb}}{R_{in}}$$

Gain > 0

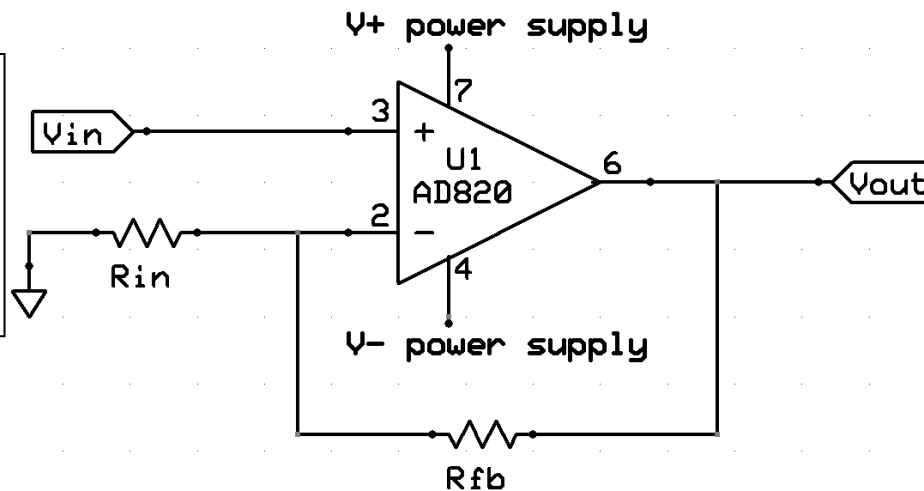



Signal Conditioning Circuit

Summing Amplifier

$$V_{out} = -\left[V_{in1} \frac{R_{fb}}{R_{in1}} + V_{in2} \frac{R_{fb}}{R_{in2}}\right]$$

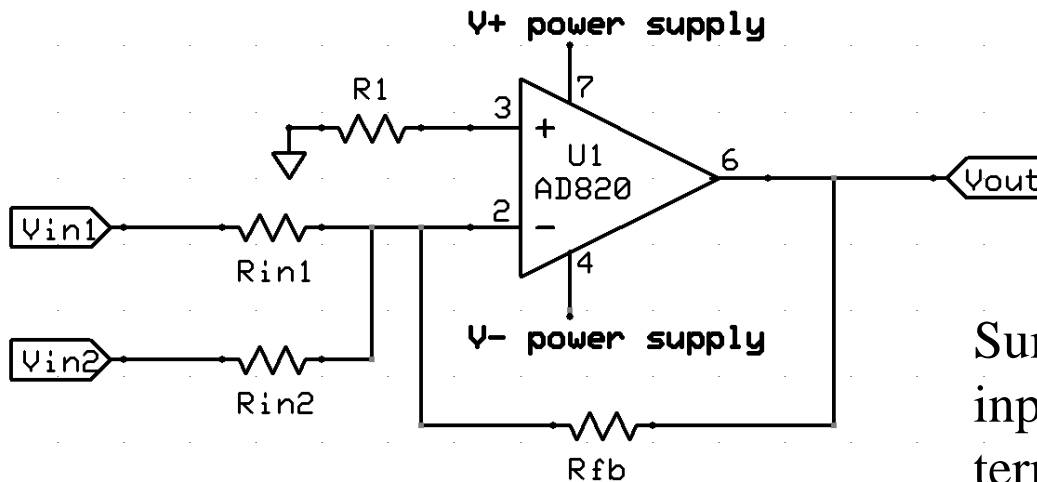

Summing op amps have multiple inputs are connected into a single terminal. Can be inverting (shown here) or noninverting.



Signal Conditioning Circuit

Difference Amplifier

$$V_{out} = (V_{in2} - V_{in1}) \left(\frac{R_f}{R1} \right) \quad \text{if } \frac{R_f}{R1} = \frac{Rg}{R2}$$

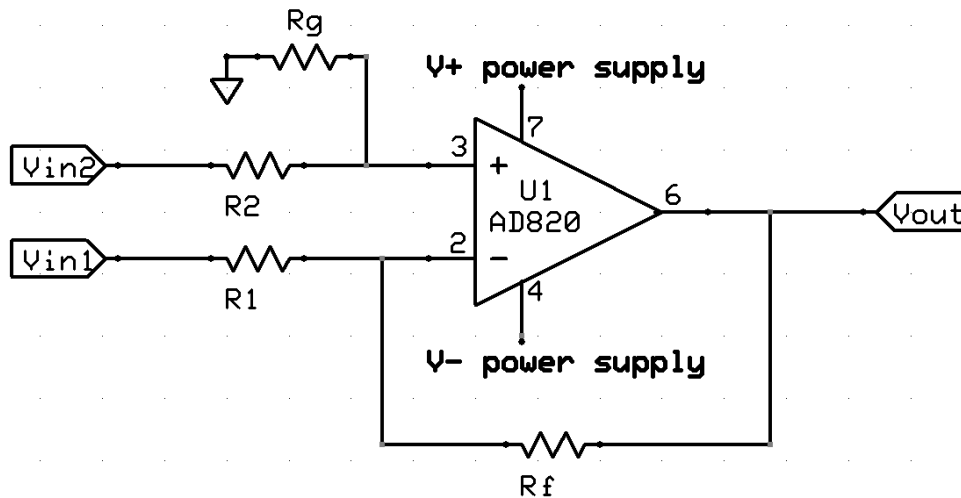

A difference op amp has an input into both the negative and positive terminals.

It amplifies the difference between the two signals.



Op Amp Circuits

- A common variation is to add an offset to previous examples which shifts the entire signal by a constant amount up and down.
- The minimum and maximum output values are limited by source V_+ and V_- .
- It is also common to have multiple stages of amplification, for example first use buffers to prevent the amplifiers from affecting the sensor signals.
- Data sheets for Op Amp ICs will often include applications showing how to calculate required values



Electronic Filters

All sensors have noise in their outputs to some degree. **Noise** is undesired variations in electronic signals.

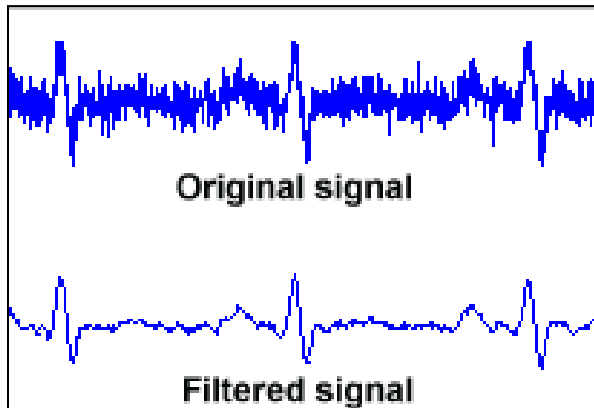

In the image above, the signal has had unwanted frequencies removed.

The rapid noise has been removed.

Electronic filters are circuits that remove unwanted noise from an applied signal and produce a cleaner signal. They may separate combined signals or restore distorted signals.

Typically remove a signal faster (**low pass**) or slower (**high pass**) than the signal you care about



Input and Output Impedance

Impedance is the resistance a circuit has to current flow when voltage is applied. Measured in Ohms. Resistance is a component of impedance. But also includes frequency dependent effects.

Input impedance is the equivalent impedance of the circuit when viewed from the input side of the circuit.

Example: The input of an oscilloscope will often be 50Ω .

Output impedance is the equivalent impedance of a circuit when viewed from the output side of the circuit.

Example: The output of a signal generator will often be 50Ω .



Impedance Matching

An **impedance mismatch** is when the input impedance and output impedance of two connected electronics differ. Impedance mismatches introduce additional noise and power loss to the system through signal reflections and other phenomenon.

Impedance matching is the practice of designing the input or output impedance of a circuit to match its corresponding signal source or load. This is often done to maximize power transfer or minimize signal reflections.



Data Acquisition Flow

