



Summary:

Student will learn how to measure electric signals using an oscilloscope. Student will generate PWM and digital outputs and attempt to view them with the oscilloscope.

Materials:

Each student team should have the following materials, equipment, and supplies:

1. Oscilloscope with probes.
2. One Arduino Mega w/ USB cable
3. A computer with Arduino IDE installed
4. Breadboard
5. Jumpers or wires
6. 2x 1K Ω Resistors (or similar)
7. Op Amp (AD820 for example)

Procedure:

- 1) Power on the oscilloscope. Boot up may take some time depending on the model.
- 2) Attach the oscilloscope probe to Channel 1.
- 3) Attach the clip of the probe to a jumper or strip of wire. Insert this jumper into one of the Arduino's ground pins.
- 4) We will use the PWM function to generate a square wave signal we can measure with the oscilloscope. Upload the following code to the Arduino Mega:

```
int PWMRate=127;
int PWMPin=4;

void setup() {
}

void loop() {
  analogWrite(PWMPin, PWMRate);

  delay (5000);
}
```

- 5) Measure the output of Pin 4 using the oscilloscope. Adjust the amplitude and time scales until a 1 kHz square wave is shown.
- 6) Change the variable PwmRate to 64. Measure the output of Pin 4. How does the signal compare to the original?

- 7) Change variable PWMRate to 192. Measure the output of Pin 4. How does the signal compare to the two previous measurements? Notice that the period of the signal does not change and is fixed. In fact, notice that the large delay we added to the loop (5 seconds) does not affect the timing of the signal, the PWM repeats on its own.
- 8) Build the following non-inverting amplifier on the breadboard. Connect Pin 4 to the input of the amplifier V_{in} by attaching a wire from the Arduino to the breadboard. (Note R1 and R2 values may be different but should be the same.)

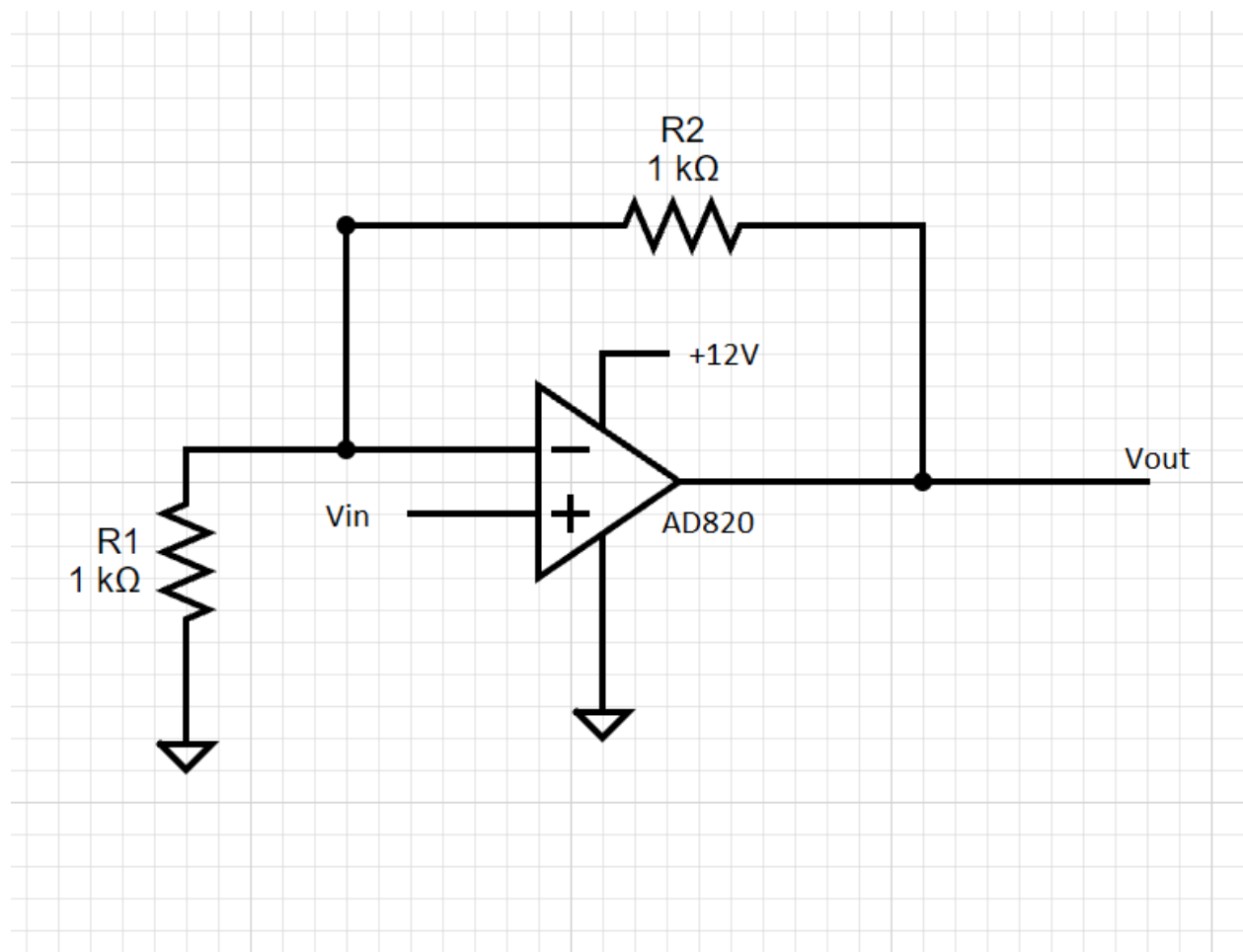

- 9) Measure the signal at the output of the amplifier. If possible, monitor the input voltage on 1 channel and the output voltage on a second channel at the same time. How do they compare?

This circuit is a non-inverting amplifier as we discussed in lecture 09.01. R1 is R_{in} and R2 is R_{fb} .



Given the equation for gain:

$$G = 1 + \frac{R_{fb}}{R_{in}}$$

We expect a gain of 2 and the signal height to be doubled. Note if the supplied voltage is not high enough the output will be limited. You can experiment with other resistor values if you have more available.