



## A04.02 SkeeterSat Assembly and Operation Manual LaACES Student Ballooning Course December 2018

J. Giammanco, N5IB



### Description

*SkeeterSat* is a simple data collection system that presents its data as audio tones. If connected to an inexpensive Family Radio Service (FRS) handheld "walkie-talkie" it forms a rudimentary radio telemetry system. Temperature and light intensity are the two physical parameters monitored.

The frequency (pitch) of the audible beep produced by *SkeeterSat* depends on the ambient temperature. The time interval between beeps depends upon the intensity of light falling on the unit.

Computer software (Spectrogram) can be used to convert the tone frequency and interval into numerical values that can be used to calculate the actual temperature and light intensity in SI units (Kelvins or Celsius degrees, and watts per square meter)

### A Little History

In 1961, just four years after the Soviet Union had stunned the world by launching SPUTNIK, the first orbiting satellite, ham radio operators in the USA convinced the Air Force to substitute a homemade satellite in place of what would have otherwise been dead-weight ballast on a Thor-Agena rocket carrying a military satellite. On December 12, 1961 OSCAR (Orbiting Satellite Carrying Amateur Radio) blasted into orbit - the first privately built orbiting spacecraft. OSCAR beeped out the friendly greeting "HI" in Morse code as the little 11-pound box circled the Earth every 92 minutes. There was some scientific value even then. As the temperature inside the craft changed, the speed of the code transmissions varied, so listeners on the ground gained insight into the space environment. After 312 orbits OSCAR re-entered the atmosphere and burned up on January 31, 1962.

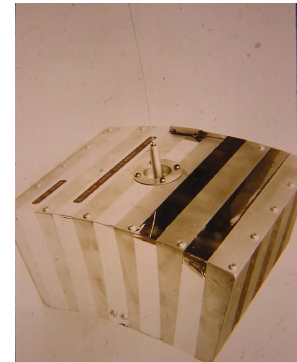

Since that day ham radio operators in several nations have cooperated to build and deploy dozens more spacecraft, most recently ECHO, also known as AMSAT-OSCAR-51 began operations. Some have a scientific mission, others are designed as communications satellites, relaying ham radio signals around the world. Almost all have incorporated telemetry systems that transmit information about the state of the onboard systems.

*SkeeterSat* evolved from *CricketSat*, a project conceived by Professor Bob Twiggs at Stanford University's Space Science Development Laboratory. The original *CricketSat* included a tiny on-board radio transmitter which transmitted a tone whose pitch varied with ambient temperature. While clearly not intended for orbit, *CricketSat* gave students a chance to experiment with telemetry, very much in the tradition of OSCAR.

The LaACES design eliminates the on-board transmitter, but provides for connection to the very popular and inexpensive FRS radios now readily available. It also adds the light sensing feature.

## Theory of operation

Refer to the schematic diagram. Integrated circuit U1 is a special function device that implements two complete timer/oscillator blocks. Values of resistance and capacitance connected to the timer control the frequency of oscillation (a stable mode on datasheet).

The combined resistances of thermistor TM1 and R8, R10, and R11, along with capacitor C2 control the frequency of one oscillator. The values are chosen to produce an audible frequency of a few hundred hertz. As the temperature changes the resistance of TM1 will change and the frequency of oscillation will vary. The higher the temperature, the lower the resistance of TM1 will be, and the higher the frequency that will be produced. The output of this oscillator is connected to a small speaker to make the tones audible.

The combined resistances of light sensor LS1 R1 R2 and R4, along with capacitor C1, form a second oscillator. The values are chosen to produce a very low frequency, around one hertz or less. This frequency is much too low for the human ear to detect, but it's not meant to be heard directly. Instead, the output of this slow oscillator is applied to transistor Q1. Acting as a switch, Q1 turns the high frequency oscillator alternately on and off, producing a repetitive beeping sound. As the intensity of the light falling on LS1 changes, its resistance will change. As the light intensity increases, the repetition rate of the beeps will increase.

The audio signal developed across C2 is sampled by transistor Q2 and presented to connector J1, where it can, if desired, be connected to a radio, tape recorder, or computer soundcard input.

Diode D1 is a protective device. If the battery is accidentally inserted backwards, D1 will prevent any current from flowing that could damage the circuit.

## Materials:

Student(s) should have the following materials, equipment, and supplies:

1. SAFETY GLASSES or GOOGLES
2. SkeeterSat kit of components and circuit board
3. A digital multimeter (DMM) capable of measuring voltage, current, and resistance
4. Soldering iron or solder station, and small diameter rosin core solder
5. 9-volt alkaline battery
6. Small tools - needle nose pliers or forceps, wire cutters (flush cutting), hobby knife, wire stripper
7. (optional) Adjustable DC power supply capable of 0-12 V, and a few hundred milliamps

The laboratory should also be equipped with the following:

1. Flat work tables sufficient to seat all students with plenty of work space

## ASSEMBLY

The vast majority of non-functioning kit-built devices can be attributed to poor soldering. The second most likely cause is installation of an incorrect component, or a correct component oriented incorrectly.

Very few non-functioning units are due to an initially defective component or subsequent failure of a component. So, if a unit does not work properly the builder should check his or her work again. It often helps to have another person inspect the work, as the builder will often gloss over a mistake that is obvious to an "impartial" inspector.

Refer to the *SkeeterSat* parts list. Locate the printed circuit board and place it with the component outlines facing up.

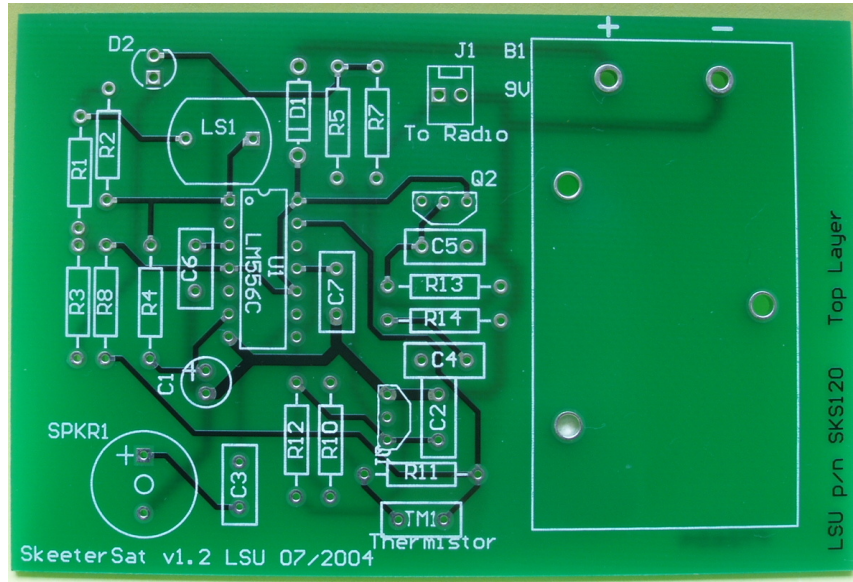

## PUT YOUR SAFETY GLASSES ON !

### Resistors

Install the following 1/4-watt, 5% carbon film resistors. Polarity is not important for resistors, but good construction practice is to arrange the color bands all in the same direction, in order that reading them is more convenient. Trim off the excess lead length after soldering. Check off each part as it is installed.

- |  |   |
|--|---|
| <input type="checkbox"/> R1 100 K (brown black yellow)                 | <input type="checkbox"/> R8 2.7K (red violet red)         |
| <input type="checkbox"/> R2 optional - not to be installed until later | <input type="checkbox"/> R9 not used in this version      |
| <input type="checkbox"/> R3 470 $\Omega$ (yellow violet brown)         | <input type="checkbox"/> R10 6.8K (blue gray red)         |
| <input type="checkbox"/> R4 27 K (red violet orange)                   | <input type="checkbox"/> R11 27K (red violet orange)      |
| <input type="checkbox"/> R5 22 K (red red orange)                      | <input type="checkbox"/> R12 1M (brown black green)       |
| <input type="checkbox"/> R6 not used in this version                   | <input type="checkbox"/> R13 10K (brown black orange)     |
| <input type="checkbox"/> R7 2.2 K (red red red)                        | <input type="checkbox"/> R14 220 $\Omega$ (red red brown) |

Inspect your work. Be sure all resistors are installed in the correct locations and that all leads are properly soldered. Be sure to check for cold solder joints or solder bridges.

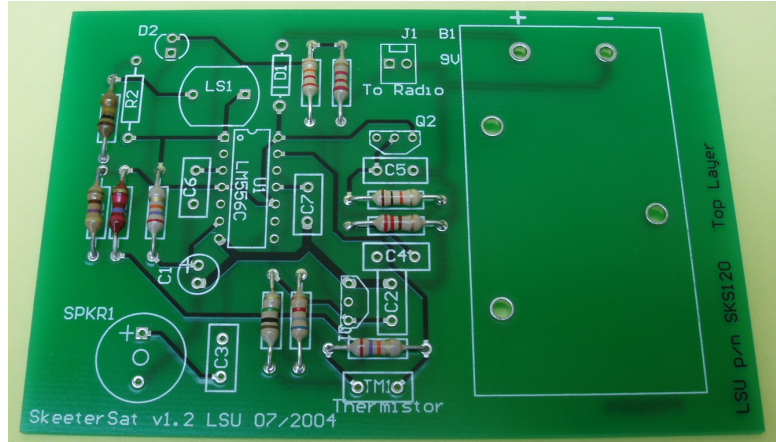

## Capacitors

Install the following monolithic ceramic capacitors. Polarity is not important. But try to orient the components so that their value marking is still visible and not obscured by other parts. Trim off the excess lead length after soldering.

- |  |  |
|--|--|
| <input type="checkbox"/> C3 0.1 $\mu$ F (marked 104) | <input type="checkbox"/> C6 0.1 $\mu$ F (marked 104) |
| <input type="checkbox"/> C4 0.1 $\mu$ F (marked 104) | <input type="checkbox"/> C7 0.1 $\mu$ F (marked 104) |

Install the following radial lead mylar capacitors. Polarity is not important. But try to orient the components so that their value marking is still visible and not obscured by other parts. Trim off the excess lead length after soldering.

- |  |
|--|
| <input type="checkbox"/> C2 0.047 $\mu$ F (marked 473) |
| <input type="checkbox"/> C5 0.047 $\mu$ F (marked 473) |

Install the radial lead, polarized electrolytic capacitor below. Be sure to observe its polarity. The longer lead is the positive lead. The leads may also be marked on the body of the component. A dark band indicates the negative lead. A positive sign may also be marked to indicate the positive lead. Trim off the excess lead length after soldering.

- |  |
|--|
| <input type="checkbox"/> C1 10 $\mu$ F |
|--|

Inspect your work. Be sure all capacitors are installed in the correct locations and that all leads are properly soldered. Inspect C1 and be sure its polarity is correct. Be sure to check for cold solder joints or solder bridges.

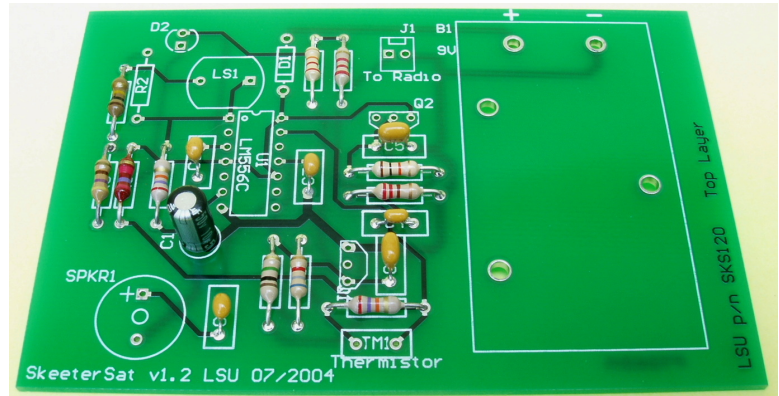

## Semiconductors

All semiconductors are polarized and must be installed with the correct orientation. The outline of the component is silk-screened on the circuit board.

Transistors are characterized by a flat on one side of the package. Install the following:

- Q1 2N3904 NPN transistor, TO-92 package
- Q2 MPF102 N-channel junction field effect transistor, TO-92 package

The rectifier diode, D1, is marked with a band around the cathode end. The silk screened outline also has a banded end. Be sure that the diode is inserted properly.

- D1 1N4001 rectifier diode

The light-emitting diode, D2, may have a flat area on one side of the package, or one lead may be longer than the other. The longer lead will be the positive (anode) end. The flattened side (if present) will be the negative (cathode) side. Install the light-emitting diode:

- D2 Red LED

Inspect your work. Be sure all semiconductors are installed in the correct locations and that all leads are properly soldered. Inspect again and be sure all polarities are correct. Be sure to check for cold solder joints or solder bridges.

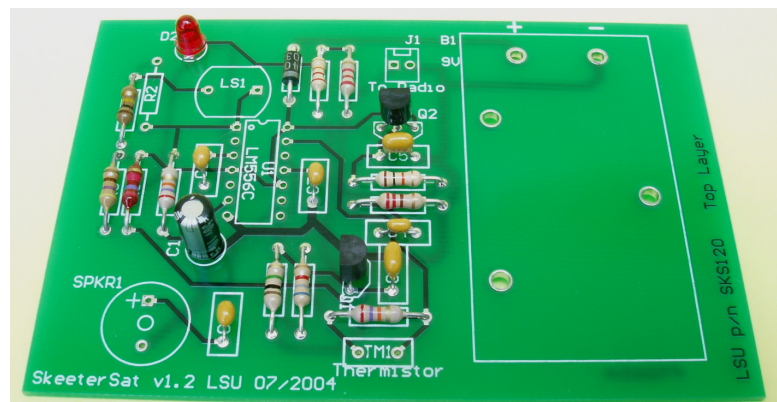

## Miscellaneous components

**Integrated circuit socket.** Install the 14 pin IC socket at U1. The silk-screened outline has a notch at one end, as does the socket. Install the socket so that the notched end matches the silk-screened outline. Solder one pin at each diagonally opposite corner of the socket and check that the socket is flat against the board. If necessary, carefully reheat the corner pins while pressing the socket against the board.

When you are sure the socket is flat, solder all of the remaining pins. DO NOT trim any excess pin length.

IC Socket

### Header connector J1.

Jumper J1 is for connecting to an external radio and will not be used.

~~Install the two pin connector at J1. The shorter pins are inserted into the circuit board. Be sure that the connector is straight and perpendicular to the board. DO NOT trim any excess lead length.~~

~~J1 connector~~

**Battery holder.** Secure the battery holder to the board with three 2-56 x 1/2" machine screws and nuts. Put the nuts on the bottom side of the board. Then solder the two pins of the battery holder and trim off excess lead length. Be very careful when trimming the leads, they are likely to fly when clipped. Protect your eyes.

Battery holder

**Speaker.** The miniature speaker is polarized. It is marked with a positive sign. Be sure to insert the positive lead into the hole marked + on the silk-screened outline. Use a minimum of soldering time/heat when soldering the speaker, as its plastic housing can be damaged by excessive heat. Trim the excess lead length, being careful to protect your eyes.

Speaker SP1

**Light sensor LS1.** Select one of the available photoresistors to use in your circuit. The light sensor is not polarized and may be installed in either orientation. It is preferable to mount the light sensor, LS1, a little bit above the surface of the board. Use heat shrink or electric tape to insulate the leads prior to soldering the sensor on to the board. Study the picture to see how the insulation is slipped over the leads of LS1 to hold it above the board.

LS1      Light sensitive resistor

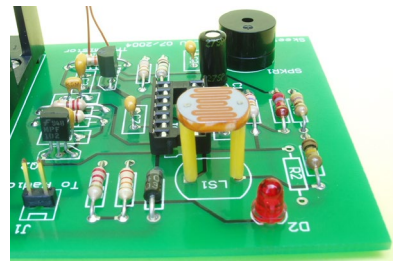

**Temperature Sensro TM1.** Select one of the available Thermistors to use in your circuit. Like the like light sensor, the temperature sensor is not polarized and may be installed in either direction. However, since we plan on performing a calibration of the temperature sensor, we need to consider how we will perform that calibration prior to installation.

To calibrate the sensor, we need to bring the sensor to known temperature. The simplest way to do that is with a water bath and an external thermometer. This presents two challenges.

First, we need to ensure the leads of the sensor are long enough to allow us to submerge the sensor. This is accomplished solder the leads of the thermistor to wires. To do so cut 2 lengths of wire (~1-2 ft long) and strip the ends. Take one of the wires and twist around one of the stripped thermistor leads. If necessary carefully strip additional wire length to give good overlap on the wires. The solder the wires together and repeat with the other lead and wire.

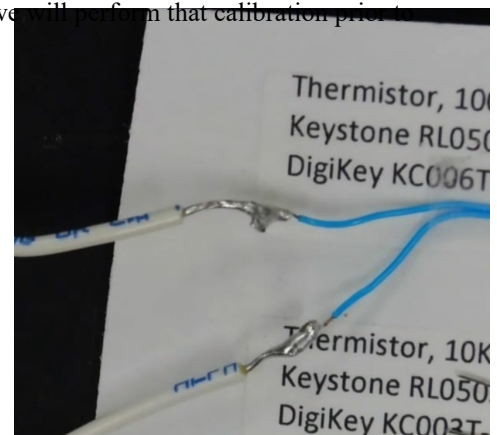

Next we need to water proof our temperature sensor. We could use either heat shrink or liquid electrical tape. If using heat shrink be sure to use a separate piece for each of the two soldered connections we just made. Then as a precaution we want cover the entire sensor with another piece of heat shrink. Alternatively, we could cover the entire sensor with liquid electrical tape. If doing so ensure the 2 soldered leads are not touching and tape the sensor down to cardboard or other surface. Liberally apply the liquid electrical tape over the soldered joints and the sensor. Allow 24 hours for the liquid electrical tape to dry before proceeding.

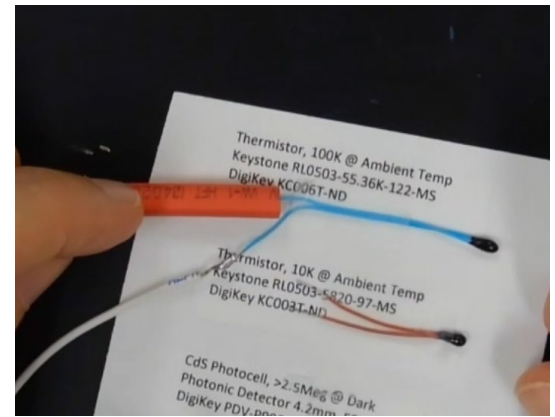

Attaching the sensor: Once the sensor has been prepared we can attach it to the board. While a 3 pin header may have been provided you do not want to solder that in to thermistor socket unless you have the tool crimp the corresponding 2 pin connector on to your sensor. If you do not you should solder the sensor leads directly on to the SkeeterSat board.

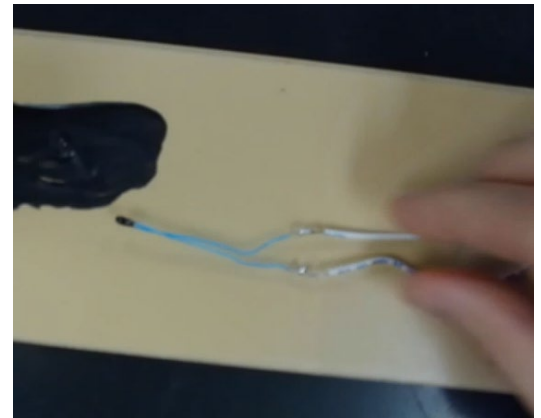

Note: the thermistor spot has 3 different through-hole pads. Looking at the back of the board we can see that the two outer pads are connected to each other. (This was done to allow a potentiometer to be soldered there as an adjustable resistor to simulate the temperature probe) This means we want to solder one of our sensor leads to the center pin and one to either of the outer pins.

TM1 Thermistor

Inspect your work. Be sure all parts are installed in the correct locations and that all leads are properly soldered. Inspect again and be sure all polarities and orientations are correct. Be sure to check for cold solder joints or solder bridges.

This completes the assembly of the *SkeeterSat*. Note that integrated circuit U1 is NOT installed at this time.

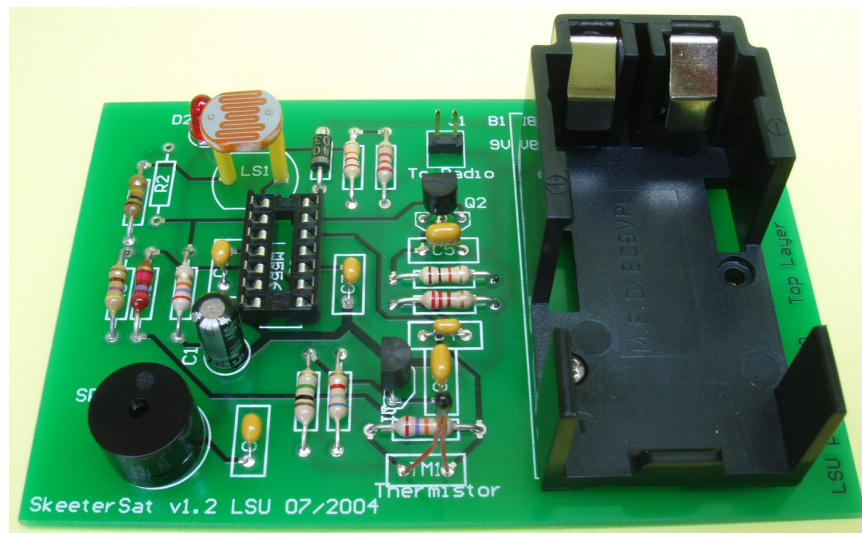

## Initial tests.

Do NOT install the integrated circuit into its socket yet. You will first make some tests to verify your assembly.

### Resistance Checks

Connect the negative lead of your multimeter to the negative terminal of the battery holder. Probe the following circuit points with the positive lead of the multimeter and record the resistance measured. The expected values in the table below are only rough estimates. Do not be concerned if your measurements differ by as much as a factor of two from these nominal values. For example: U1-5 means touch pin 5 of the 556 integrated circuit, U1, and any resistance greater than 1 Mega-ohm is acceptable.

Pin No.	Expected Value	Measured Value	Pin No.	Expected Value	Measured Value
U1-1	> 100K		U1-8	25 K	
U1-2	> 100K		U1-9	> 1 M	
U1-3	> 1M		U1-10	10 K	
U1-4	10K		U1-11	> 1 M	
U1-5	> 1M		U1-12	25 K	
U1-6	>100 K		U1-13	13 K	
U1-7	< 10 $\Omega$		U1-14	10 K	

### Voltage checks

Battery installation. Notice the + and - signs on the silk-screened outline of the battery holder. Press a 9 volt battery into the holder with the positive terminal connected to the + terminal of the holder. The + terminal of a 9 volt battery is the smaller of the two terminal on the end of the battery. Notice that there is no ON-OFF switch. You will ust remove the battery when you wish to turn the unit off.

Hold the negative (black) lead of your multimeter on the negative terminal of the battery holder. Touch the positive (red) lead of the multimeter to the following circuit points and verify the voltages in the table below. Once again, these are nominal values and variation of a volt or so are no case for concern.

Pin No.	Expected Value	Measured Value	Pin No.	Expected Value	Measured Value
U1-1	9 V		U1-8	< 1 V	
U1-2	9 V		U1-9	< 1 V	
U1-3	< 1 V		U1-10	9 V	
U1-4	8 V		U1-11	< 1 V	
U1-5	7 V		U1-12	< 1 V	
U1-6	9 V		U1-13	7 V	
U1-7	< 1 V		U1-14	9 V	

Remove the battery from the battery holder. This completes the preliminary testing.

### Final tests

Install the integrated circuit, U1, into its socket. You may need to gently form the leads to allow then to fit easily into the socket. Be sure to align the notch near pin 1 of the chip with the notch in the socket. Press the chip firmly into the socket.

Reinstall the battery. Within a few seconds you two fingers. You should hear the pitch of the beeps increase. Cover the light sensor with a card or other opaque object. The interval between beeps should increase.

If all is as described above, CONGRATULATIONS. You've built a working *SkeeterSat*. Now, you are ready to work on calibration.



## Operation

<b>SkeeterSat Packing List</b>			
Designator	Parts in outer envelope	Part Number	
1 PCB	Printed circuit Board	LSU	
1 BH1	Battery holder PC mount 9 V battery holder (DigiKey BC9VPC-ND)	Digikey BC9VPC	
4 FEET	0.5" x 0.5" x 0.25" black (DigiKey SJ-5518-0-ND)	Digikey SJ-5003	
<b>Contents of small envelope</b>			
1 R1	100K 1/4 W 5%	Digikey 100KQBK	
1 R2	TBD		
1 R3	470 1/4 W 5%	Digikey 470QBK	
2 R4, R11	27K 1/4 W 5%	Digikey 27KQBK	
1 R5	22k 1/4 W 5%	Digikey 22KQBK	
1 R7	2.2K 1/4 W 5%	Digikey 2.2KQBK	
1 R8	2.7K 1/4 W 5%	Digikey 2.7KQBK	
1 R10	6.8K 1/4 W 5%	Digikey 6.8KQBK	
1 R12	1M 1/4 W 5%	Digikey 1.0MQBK	
1 R13	10K 1/4 W 5%	Digikey 10KQBK	
1 R14	220 1/4 W 5%	Digikey 220QBK	
1 C1	10 uF radial lead electrolytic	Digikey P11250	
2 C2, C5	.047 uF, 0.2" lead spacing, radial	Digikey 399-4370	
4 C3, C4, C6, C7	.1 uF monolithic ceramic, radial lead	Digikey 399-4330	
1 D1	1N4001 DO-35 rectifier	Digikey 1N4001DICT	
1 D2	Red LED 0.1 lead spacing	Digikey 67-1065	
1 J1	.1" Male Header, 2 pin square post (not required - optional)		
3 2-56 x 1/2 machine screw	DigiKey H334-ND (Phillips) or H134-ND (slotted)	Digikey H330	
3 2-56 hex nut	DigiKey H212-ND	Digikey H212	
1 Header for Thermistor	.1" Male Header, 3 pin square post		
<b>Packed on black anti-static foam</b>			
1 U1	TLC556CN dual CMOS timer (DigiKey 296-1859-5-ND)	Digikey 296-1859-5	
1 Q1	2N3904 TO-92	Digikey 497-2395	
1 Q2	J109FS TO-92	Digikey J109FS-ND	
1 SPKR1	Speaker - Soberton GT-111P (DigiKey 422-1020-ND)	Digikey 433-1020	
1	Socket, DIP 14-pin	Digikey AE10012	
<b>Taped on an index card.</b>			
1 TM1A	Thermistor, 10K ambient, Keystone RL0503-5820-97-MS (DigiKey KC003T-ND)	Digikey KC003T or equiv	
1 TM1B	Thermistor, 100K ambient, NTCLE100E3104JB0 KC006T or similar	DigiKey KC006T or equiv	
1 LS1A	CdS Sensor, 2 M dark, Photonic Detectors 27~60K (DigiKey PDV-P8104)	Digikey PDV-P5003 or equiv	
1 LS1B	CdS Sensor, 2.5 M dark, Photonic Detectors 50~94K (DigiKey PDV-P9005-ND)	Digikey PDV-P9005 or equiv	

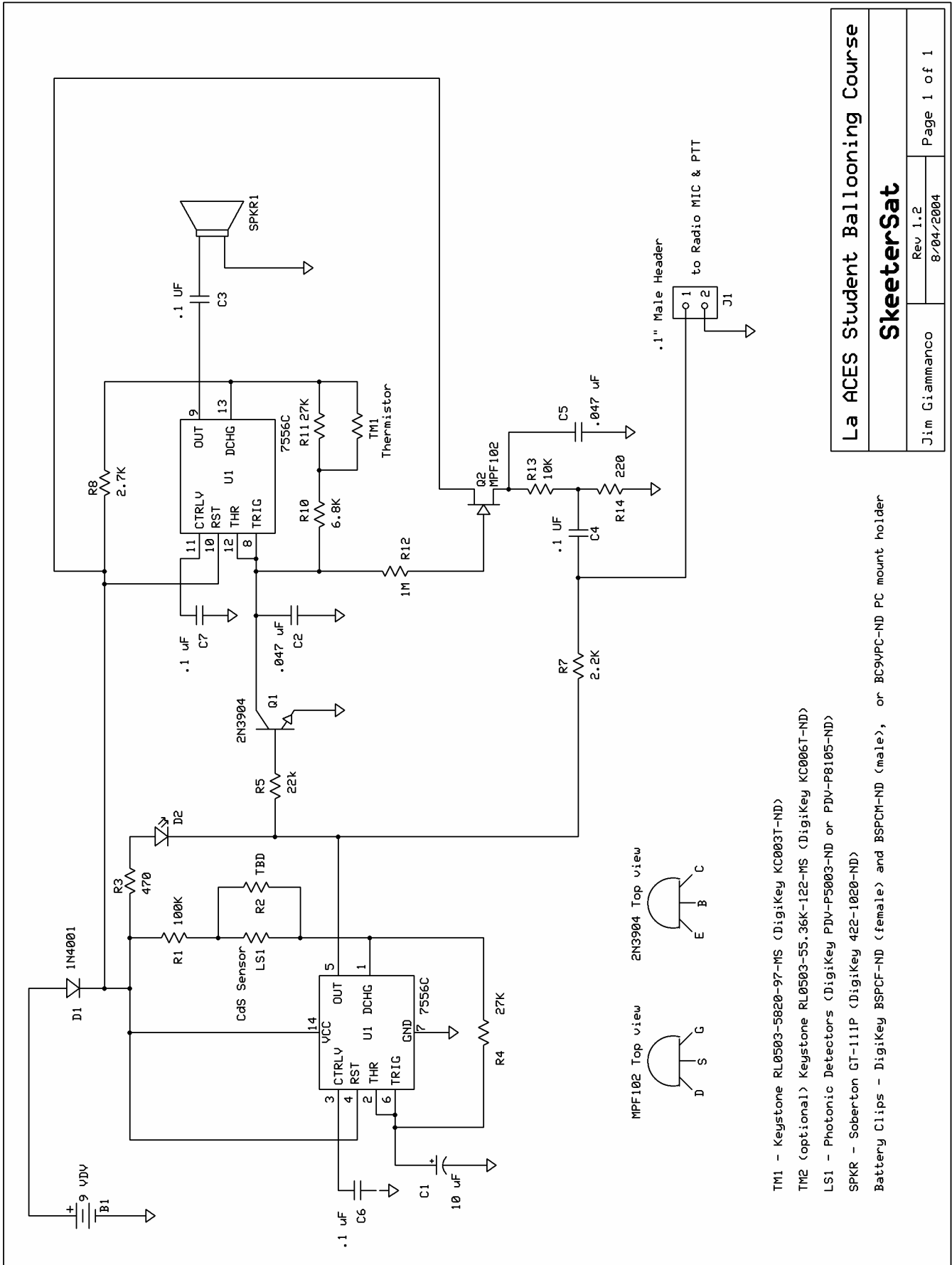

TM1 - Keystone RL0503-5620-97-MS (DigiKey KC003T-ND)

TM2 (optional) Keystone RL0503-55.36K-122-MS (DigiKey KC006T-ND)

LS1 - Photonic Detectors (DigiKey PJDV-F5003-ND or PJDV-P8105-ND)

SPKR - Sobotron GT-111P (DigiKey 422-1020-ND)

Battery Clips - DigiKey BSPCF-ND (female) and BSPCH-ND (male), or BC9VPC-ND PC mount holder

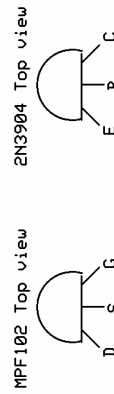

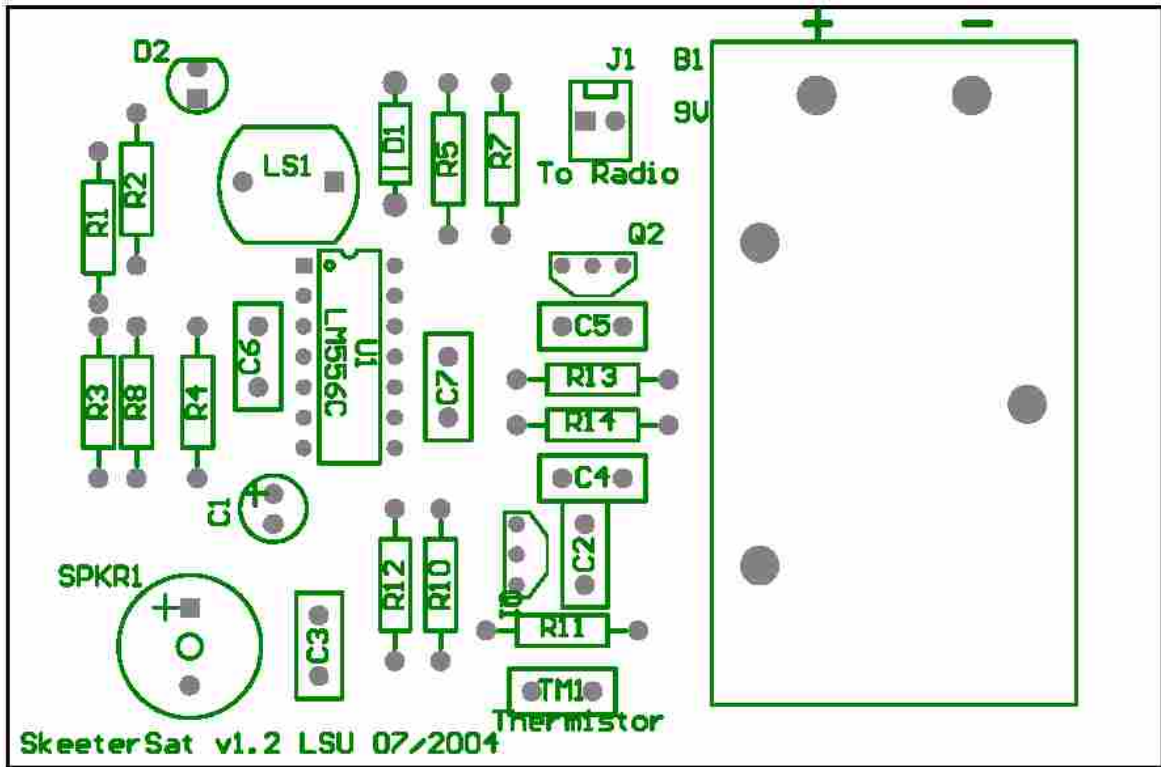

SkeeterSat component placement diagrams, silks screen (above) and copper (below)

