



## A04.02 SkeeterSat Assembly and Operation Manual LaACES Student Ballooning Course December 2018

J. Giammanco, N5IB



### Description

*SkeeterSat* is a simple data collection system that presents its data as audio tones. If connected to an inexpensive Family Radio Service (FRS) handheld "walkie-talkie" it forms a rudimentary radio telemetry system. Temperature and light intensity are the two physical parameters monitored.

The frequency (pitch) of the audible beep produced by *SkeeterSat* depends on the ambient temperature. The time interval between beeps depends upon the intensity of light falling on the unit.

Computer software (Spectrogram) can be used to convert the tone frequency and interval into numerical values that can be used to calculate the actual temperature and light intensity in SI units (Kelvins or Celsius degrees, and watts per square meter)

### A Little History

In 1961, just four years after the Soviet Union had stunned the world by launching SPUTNIK, the first orbiting satellite, ham radio operators in the USA convinced the Air Force to substitute a homemade satellite in place of what would have otherwise been dead-weight ballast on a Thor-Agena rocket carrying a military satellite. On December 12, 1961 OSCAR (Orbiting Satellite Carrying Amateur Radio) blasted into orbit - the first privately built orbiting spacecraft. OSCAR beeped out the friendly greeting "HI" in Morse code as the little 11-pound box circled the Earth every 92 minutes. There was some scientific value even then. As the temperature inside the craft changed, the speed of the code transmissions varied, so listeners on the ground gained insight into the space environment. After 312 orbits OSCAR re-entered the atmosphere and burned up on January 31, 1962.

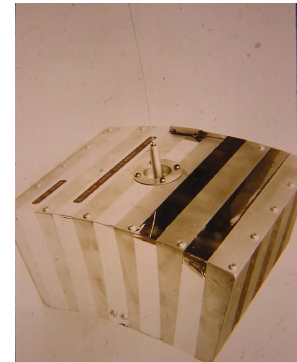

Since that day ham radio operators in several nations have cooperated to build and deploy dozens more spacecraft, most recently ECHO, also known as AMSAT-OSCAR-51 began operations. Some have a scientific mission, others are designed as communications satellites, relaying ham radio signals around the world. Almost all have incorporated telemetry systems that transmit information about the state of the onboard systems.

*SkeeterSat* evolved from *CricketSat*, a project conceived by Professor Bob Twiggs at Stanford University's Space Science Development Laboratory. The original *CricketSat* included a tiny on-board radio transmitter which transmitted a tone whose pitch varied with ambient temperature. While clearly not intended for orbit, *CricketSat* gave students a chance to experiment with telemetry, very much in the tradition of OSCAR.

The LaACES design eliminates the on-board transmitter, but provides for connection to the very popular and inexpensive FRS radios now readily available. It also adds the light sensing feature.

## Theory of operation

Refer to the schematic diagram. Integrated circuit U1 is a special function device that implements two complete timer/oscillator blocks. Values of resistance and capacitance connected to the timer control the frequency of oscillation (a stable mode on datasheet).

The combined resistances of thermistor TM1 and R8, R10, and R11, along with capacitor C2 control the frequency of one oscillator. The values are chosen to produce an audible frequency of a few hundred hertz. As the temperature changes the resistance of TM1 will change and the frequency of oscillation will vary. The higher the temperature, the lower the resistance of TM1 will be, and the higher the frequency that will be produced. The output of this oscillator is connected to a small speaker to make the tones audible.

The combined resistances of light sensor LS1 R1 R2 and R4, along with capacitor C1, form a second oscillator. The values are chosen to produce a very low frequency, around one hertz or less. This frequency is much too low for the human ear to detect, but it's not meant to be heard directly. Instead, the output of this slow oscillator is applied to transistor Q1. Acting as a switch, Q1 turns the high frequency oscillator alternately on and off, producing a repetitive beeping sound. As the intensity of the light falling on LS1 changes, its resistance will change. As the light intensity increases, the repetition rate of the beeps will increase.

The audio signal developed across C2 is sampled by transistor Q2 and presented to connector J1, where it can, if desired, be connected to a radio, tape recorder, or computer soundcard input.

Diode D1 is a protective device. If the battery is accidentally inserted backwards, D1 will prevent any current from flowing that could damage the circuit.

Please refer to the Excel spreadsheet <*SkeeterSat.xls*>. This spreadsheet can be used to calculate the frequencies of oscillation as the values of resistance and capacitance in the circuit are varied.

## Materials:

Student(s) should have the following materials, equipment, and supplies:

1. SAFETY GLASSES or GOOGLES
2. SkeeterSat kit of components and circuit board
3. A digital multimeter (DMM) capable of measuring voltage, current, and resistance
4. Soldering iron or solder station, and small diameter rosin core solder
5. 9-volt alkaline battery
6. Small tools - needle nose pliers or forceps, wire cutters (flush cutting), hobby knife
7. (optional) Adjustable DC power supply capable of 0-12 V, and a few hundred milliamps

The laboratory should also be equipped with the following:

1. Flat work tables sufficient to seat all students with plenty of work space
2. One or more computers with sound card and microphone, and Spectrogram software installed.

## ASSEMBLY

The vast majority of non-functioning kit-built devices can be attributed to poor soldering. The second most likely cause is installation of an incorrect component, or a correct component oriented incorrectly.

Very few non-functioning units are due to an initially defective component or subsequent failure of a component. So, if a unit does not work properly the builder should check his or her work again. It often helps to have another person inspect the work, as the builder will often gloss over a mistake that is obvious to an "impartial" inspector.

Refer to the *SkeeterSat* parts list. Locate the printed circuit board and place it with the component outlines facing up.

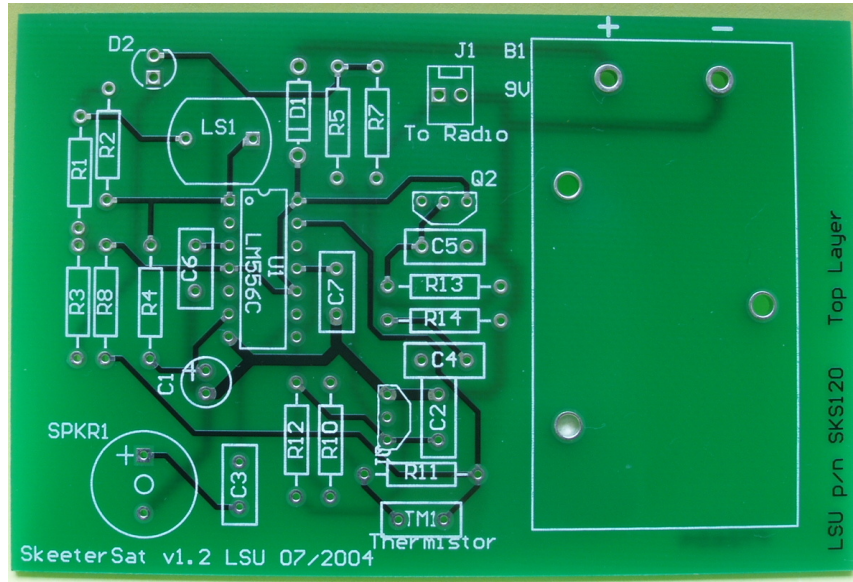

## PUT YOUR SAFETY GLASSES ON !

### Resistors

Install the following 1/4-watt, 5% carbon film resistors. Polarity is not important for resistors, but good construction practice is to arrange the color bands all in the same direction, in order that reading them is more convenient. Trim off the excess lead length after soldering. Check off each part as it is installed.

- |  |   |
|--|---|
| <input type="checkbox"/> R1 100 K (brown black yellow)                 | <input type="checkbox"/> R8 2.7K (red violet red)         |
| <input type="checkbox"/> R2 optional - not to be installed until later | <input type="checkbox"/> R9 not used in this version      |
| <input type="checkbox"/> R3 470 $\Omega$ (yellow violet brown)         | <input type="checkbox"/> R10 6.8K (blue gray red)         |
| <input type="checkbox"/> R4 27 K (red violet orange)                   | <input type="checkbox"/> R11 27K (red violet orange)      |
| <input type="checkbox"/> R5 22 K (red red orange)                      | <input type="checkbox"/> R12 1M (brown black green)       |
| <input type="checkbox"/> R6 not used in this version                   | <input type="checkbox"/> R13 10K (brown black orange)     |
| <input type="checkbox"/> R7 2.2 K (red red red)                        | <input type="checkbox"/> R14 220 $\Omega$ (red red brown) |

Inspect your work. Be sure all resistors are installed in the correct locations and that all leads are properly soldered. Be sure to check for cold solder joints or solder bridges.

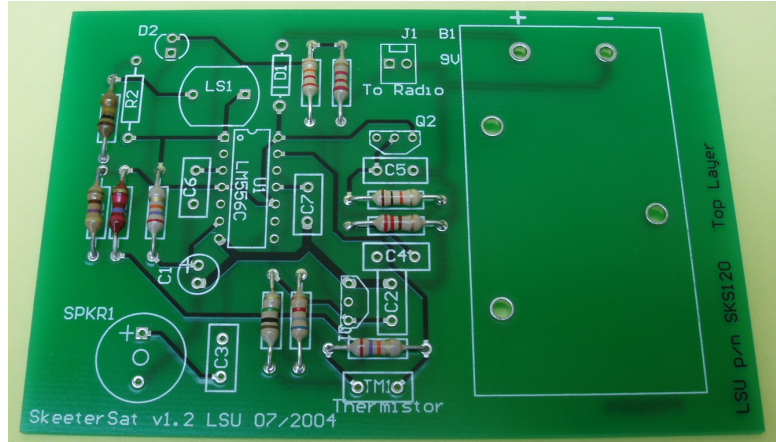

## Capacitors

Install the following monolithic ceramic capacitors. Polarity is not important. But try to orient the components so that their value marking is still visible and not obscured by other parts. Trim off the excess lead length after soldering.

- |  |  |
|--|--|
| <input type="checkbox"/> C3 0.1 $\mu$ F (marked 104) | <input type="checkbox"/> C6 0.1 $\mu$ F (marked 104) |
| <input type="checkbox"/> C4 0.1 $\mu$ F (marked 104) | <input type="checkbox"/> C7 0.1 $\mu$ F (marked 104) |

Install the following radial lead mylar capacitors. Polarity is not important. But try to orient the components so that their value marking is still visible and not obscured by other parts. Trim off the excess lead length after soldering.

- |  |
|--|
| <input type="checkbox"/> C2 0.047 $\mu$ F (marked 473) |
| <input type="checkbox"/> C5 0.047 $\mu$ F (marked 473) |

Install the radial lead, polarized electrolytic capacitor below. Be sure to observe its polarity. The longer lead is the positive lead. The leads may also be marked on the body of the component. A dark band indicates the negative lead. A positive sign may also be marked to indicate the positive lead. Trim off the excess lead length after soldering.

- |  |
|--|
| <input type="checkbox"/> C1 10 $\mu$ F |
|--|

Inspect your work. Be sure all capacitors are installed in the correct locations and that all leads are properly soldered. Inspect C1 and be sure its polarity is correct. Be sure to check for cold solder joints or solder bridges.

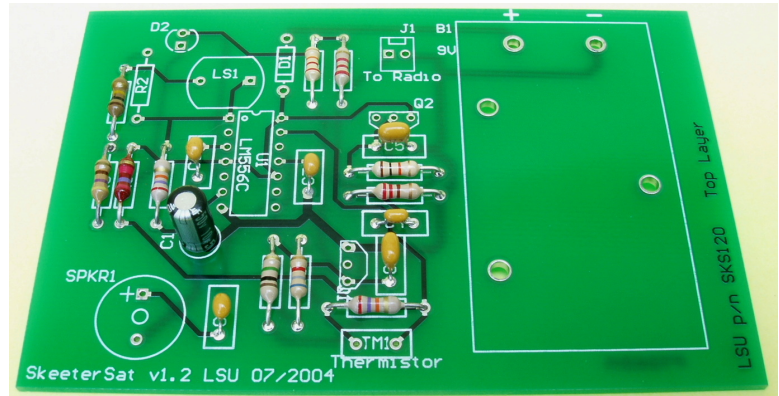

## Semiconductors

All semiconductors are polarized and must be installed with the correct orientation. The outline of the component is silk-screened on the circuit board.

Transistors are characterized by a flat on one side of the package. Install the following:

- Q1 2N3904 NPN transistor, TO-92 package
- Q2 MPF102 N-channel junction field effect transistor, TO-92 package

The rectifier diode, D1, is marked with a band around the cathode end. The silk screened outline also has a banded end. Be sure that the diode is inserted properly.

- D1 1N4001 rectifier diode

The light-emitting diode, D2, may have a flat area on one side of the package, or one lead may be longer than the other. The longer lead will be the positive (anode) end. The flattened side (if present) will be the negative (cathode) side. Install the light-emitting diode:

- D2 Red LED

Inspect your work. Be sure all semiconductors are installed in the correct locations and that all leads are properly soldered. Inspect again and be sure all polarities are correct. Be sure to check for cold solder joints or solder bridges.

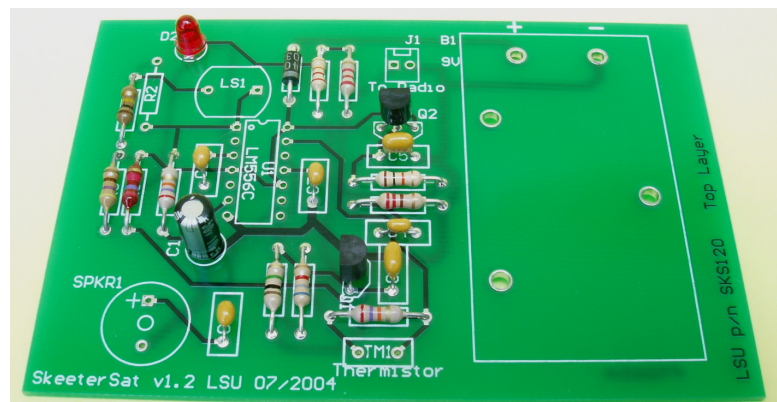



## Miscellaneous components

**Integrated circuit socket.** Install the 14 pin IC socket at U1. The silk-screened outline has a notch at one end, as does the socket. Install the socket so that the notched end matches the silk-screened outline. Solder one pin at each diagonally opposite corner of the socket and check that the socket is flat against the board. If necessary, carefully reheat the corner pins while pressing the socket against the board.

When you are sure the socket is flat, solder all of the remaining pins. DO NOT trim any excess pin length.

IC Socket

**Header connector.** Install the two-pin connector at J1. The shorter pins are inserted into the circuit board. Be sure that the connector is straight and perpendicular to the board. DO NOT trim any excess lead length.

J1 connector

**Battery holder.** Secure the battery holder to the board with three 2-56 x 1/2" machine screws and nuts. Put the nuts on the bottom side of the board. Then solder the two pins of the battery holder and trim off excess lead length. Be very careful when trimming the leads, they are likely to fly when clipped. Protect your eyes.

Battery holder

**Speaker.** The miniature speaker is polarized. It is marked with a positive sign. Be sure to insert the positive lead into the hole marked + on the silk-screened outline. Use a minimum of soldering time/heat when soldering the speaker, as its plastic housing can be damaged by excessive heat. Trim the excess lead length, being careful to protect your eyes.

Speaker SP1

**The two sensor components,** a light sensor and a thermistor, are not polarized and may be installed in either orientation. It is preferable to mount the light sensor, LS1, a little bit above the surface of the board. Strip off some plastic insulation from a short length of hookup wire. Study the picture to see how the insulation is slipped over the leads of LS1 to hold it above the board.

TM1 Thermistor

LS1 Light sensitive resistor

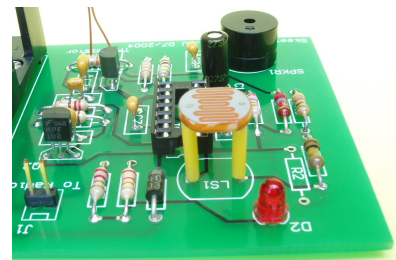

Inspect your work. Be sure all parts are installed in the correct locations and that all leads are properly soldered. Inspect again and be sure all polarities and orientations are correct. Be sure to check for cold solder joints or solder bridges.

This completes the assembly of the *SkeeterSat*. Note that integrated circuit U1 is NOT installed at this time.

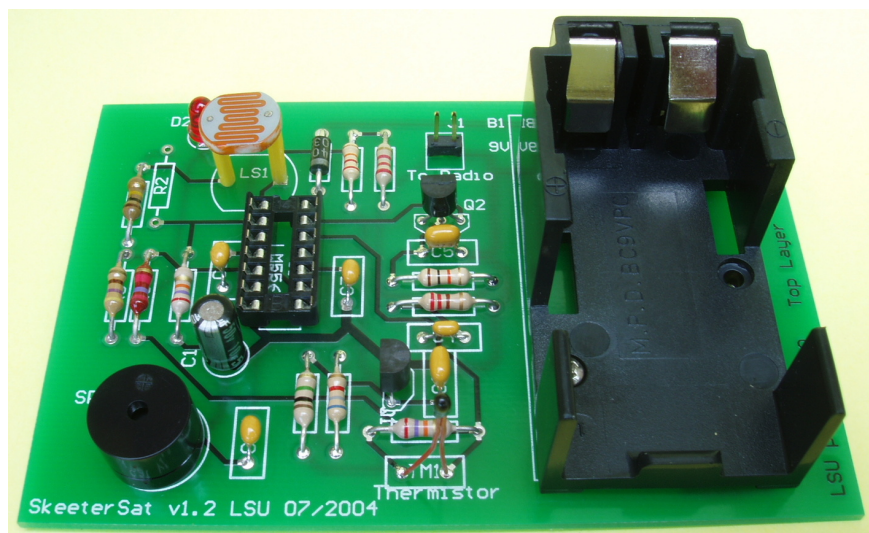

## Initial tests.

Do NOT install the integrated circuit into its socket yet. You will first make some tests to verify your assembly.

### Resistance Checks

Connect the negative lead of your multimeter to the negative terminal of the battery holder. Probe the following circuit points with the positive lead of the multimeter and record the resistance measured. The expected values in the table below are only rough estimates. Do not be concerned if your measurements differ by as much as a factor of two from these nominal values. For example: U1-5 means touch pin 5 of the 556 integrated circuit, U1, and any resistance greater than 1 Mega-ohm is acceptable.

Pin No.	Expected Value	Measured Value	Pin No.	Expected Value	Measured Value
U1-1	> 100K		U1-8	25 K	
U1-2	> 100K		U1-9	> 1 M	
U1-3	> 1M		U1-10	10 K	
U1-4	10K		U1-11	> 1 M	
U1-5	> 1M		U1-12	25 K	
U1-6	>100 K		U1-13	13 K	
U1-7	< 10 $\Omega$		U1-14	10 K	

### Voltage checks

Battery installation. Notice the + and - signs on the silk-screened outline of the battery holder. Press a 9 volt battery into the holder with the positive terminal connected to the + terminal of the holder. The + terminal of a 9 volt battery is the smaller of the two terminal on the end of the battery. Notice that there is no ON-OFF switch. You will just remove the battery when you wish to turn the unit off.

Hold the negative (black) lead of your multimeter on the negative terminal of the battery holder. Touch the positive (red) lead of the multimeter to the following circuit points and verify the voltages in the table below. Once again, these are nominal values and variation of a volt or so are no case for concern.

Pin No.	Expected Value	Measured Value	Pin No.	Expected Value	Measured Value
U1-1	9 V		U1-8	< 1 V	
U1-2	9 V		U1-9	< 1 V	
U1-3	< 1 V		U1-10	9 V	
U1-4	8 V		U1-11	< 1 V	
U1-5	7 V		U1-12	< 1 V	
U1-6	9 V		U1-13	7 V	
U1-7	< 1 V		U1-14	9 V	

Remove the battery from the battery holder. This completes the preliminary testing.

### Final tests

Install the integrated circuit, U1, into its socket. You may need to gently form the leads to allow them to fit easily into the socket. Be sure to align the notch near pin 1 of the chip with the notch in the socket. Press the chip firmly into the socket.

Reinstall the battery. Within a few seconds you two fingers. You should hear the pitch of the beeps increase. Cover the light sensor with a card or other opaque object. The interval between beeps should increase.

If all is as described above, CONGRATULATIONS. You've built a working *SkeeterSat*. Now, what can you do with it?

## Operation

While you can just listen to *SkeeterSat* beeping happily, some means of reducing the beeps to numerical data is needed if this simple telemetry system is to have meaning. The *Spectrogram* program provides that tool.

On a flash drive or other storage device provided by LaACES you will find a folder called *Spectrogram*. Copy the files from the *Spectrogram* folder to your computers hard drive. No installation process is needed, you can just launch the application <gram.exe> Be sure you have a microphone connected to your computer's soundcard input, and that the microphone recording input is enabled, with its volume slider set about halfway to maximum. Place the microphone close to *SkeeterSat's* speaker.

The first thing you will encounter is a setup screen like the one pictured. For now, just click the appropriate button to make your setup the same as the one shown.

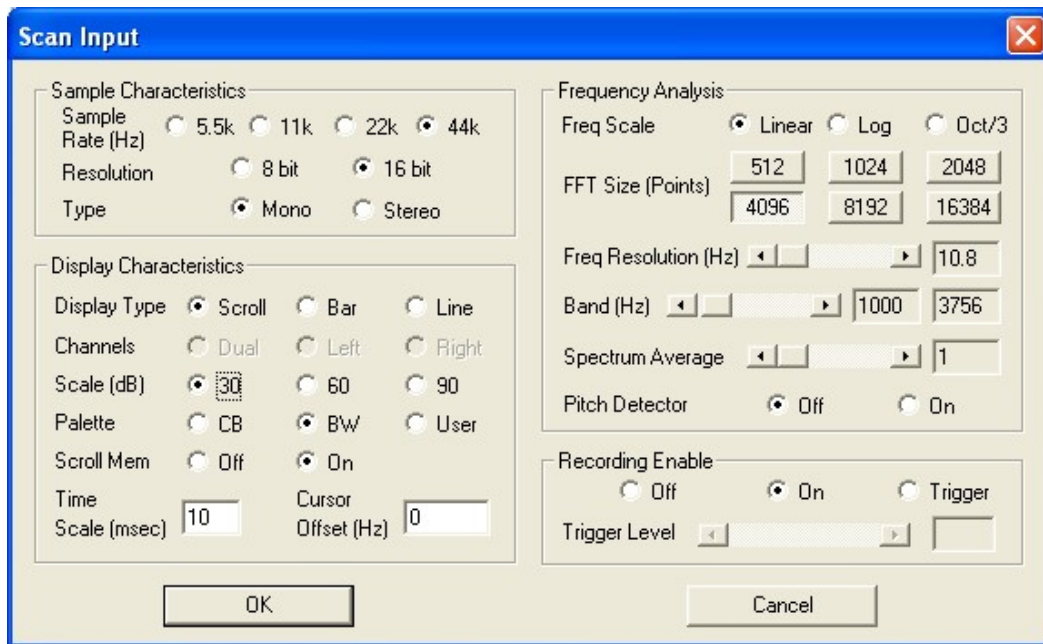

When you click <OK> you will be prompted for a filename to be used to save a wav file. Enter a name of your choosing and click <SAVE>

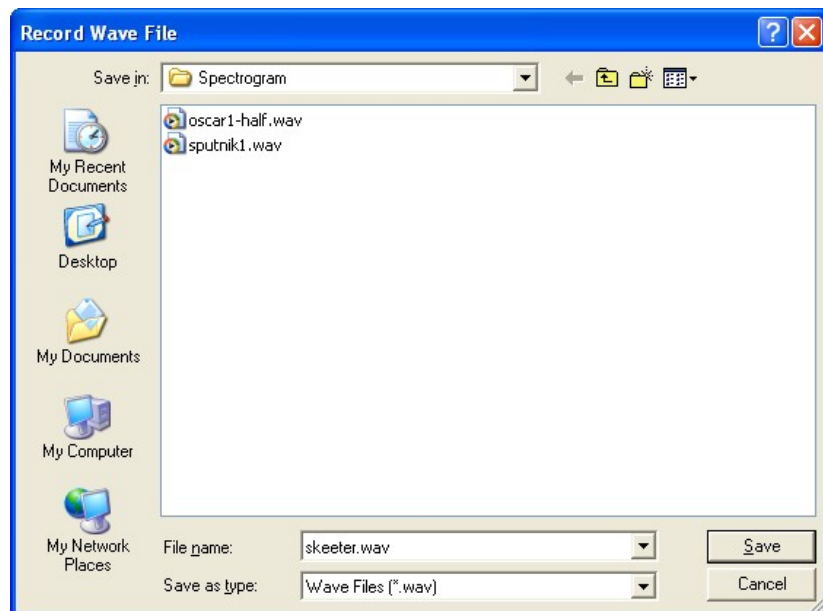



A pattern similar to the one pictured next should begin scrolling across your screen.

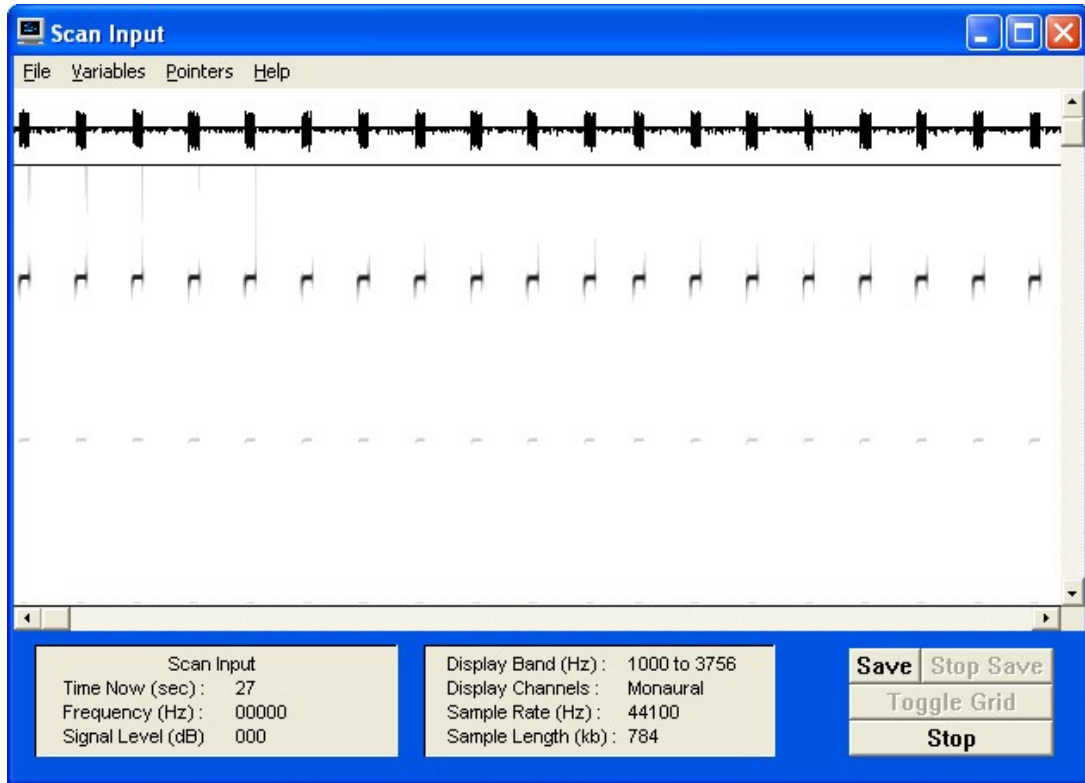

Click <STOP> then wait a few seconds for the program to respond.  
Now click <TOGGLE GRID> and you should see the following display.

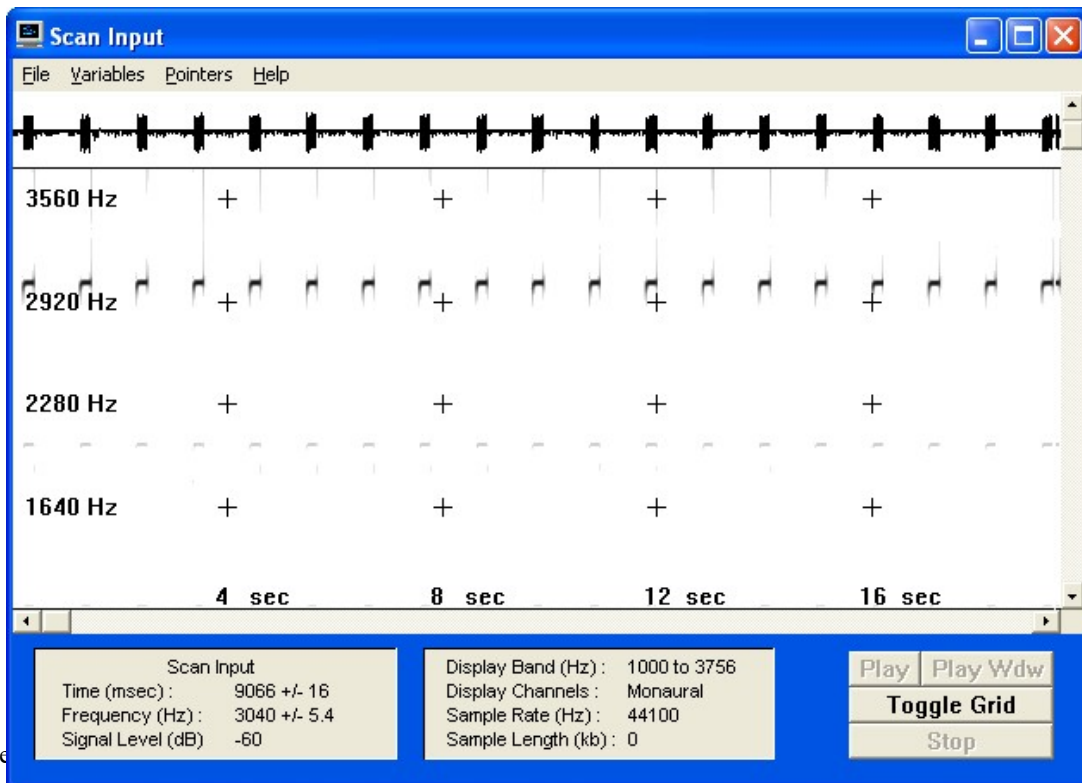

As you move the cursor around the screen notice how the box in the lower left shows you the time, frequency, and amplitude of the recorded signal. This is the tool you need to make meaningful measurements with *SkeeterSat*. *Spectrogram* has many other features and capabilities. Spend some time reading through the HELP file within the program.

## Using *SkeeterSat* with a Radio Transmitter

If a pair of inexpensive *Family Radio Service* (FRS) walkie-talkies is available, it is possible to *SkeeterSat* to one of the radios in such a way that the audio beeps will be transmitted to the remotely located second walkie-talkie. Transmissions of a mile or more be possible depending on the openness of the terrain between units. Over open water, several miles are possible.

Many FRS radios have a 2.5 mm miniature 2-conductor microphone jack and a 3.5 mm miniature earphone jack. A cable connecting J1 on the *SkeeterSat* board to the microphone jack should provide the correct signal to transmit the beeps. You may need to experiment with the resistor values that set the duration and interval of *SkeeterSat*'s beeps to accommodate any lag time in the radio switching from receive to transmit.

Some newer FRS radios have a single 2.5 mm miniature stereo jack that serves for both microphone and earphone. Experiments are under way to determine how best to connect *SkeeterSat* to that type radio.

## References:

Manufacturer's data sheets for

556 dual timer	<TLC555 Datasheet.pdf>
light sensor	<P5003 Photosensor.pdf> and <P8105 Photosensor.pdf>
thermistor	<RL0503 Series Thermistors.pdf>
2N3904 transistor	<2N3904.pdf>
MPF102 transistor	<MPF102.pdf>
miniature speaker	<Mini Speaker.pdf>
battery holder	<Battery Holder.pdf>
1N4001 diode	<1N4000 Series Diodes.pdf>

Spectrogram audio signal analysis program, executable file  
(A Help file is accessible when the program is running) <gram.exe>

<b>SkeeterSat bill of materials</b>	
B1	9 volt alkaline battery
BH1	Battery holder PC mount 9 V battery holder (DigiKey BC9VPC-ND)
C1	10 uF radial lead electrolytic, 0.1" spacing
C2, C5	.047 uF, 0.2" lead spacing, radial
C3, C4, C6, C7	.1 UF monolithic ceramic, 0.2" lead spacing, radial
D1	1N4001 DO-41 rectifier
D2	water clear red T-1 LED 0.1 lead spacing, (DigiKey 67-1065-ND)
J1	.1" Male Header, 2 pin square post (DigiKey WM4200-ND, mates with WM-2011-ND)
LS1A	CdS Sensor, I M dark, Photonic Detectors (DigiKey PDV-P5003-ND)
LS1B	CdS Sensor, 2.5 M dark, Photonic Detectors (DigiKey PDV-P8105-ND)
Q1	2N3904 TO-92
Q2	MPF102 TO-92
R1	100K 1/4 W 5%
R2	to be determined later
R3	470 1/4 W 5%
R4, R11	27K 1/4 W 5%
R5	22k 1/4 W 5%
R7	2.2K 1/4 W 5%
R8	2.7K 1/4 W 5%
R10	6.8K 1/4 W 5%
R12	1M 1/4 W 5%
R13	10K 1/4 W 5%
R14	220 1/4 W 5%
SPKR1	Speaker - Soberton GT-111P (DigiKey 422-1020-ND)
TM1A	Thermistor, 10K ambient, Keystone RL0503-5820-97-MS (DigiKey KC003T-ND)
TM1B	Thermistor, 100K ambient, Keystone RL0503-55.36K-122-MS (DigiKey KC006T-ND)
U1	TLC556CN dual CMOS timer (DigiKey 296-1859-5-ND)
FEET	0.40" diameter x 0.20" H feet, black (DigiKey SJ5003-0-ND)
PCB	Printed circuit Board
2-56 x 1/4 machine screw	DigiKey H330-ND (Phillips) or H130-ND (slotted)
2-56 hex nut	DigiKey H212-ND

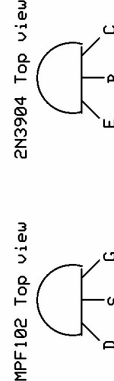
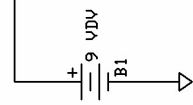

- TM1 - Keystone RL0503-5620-97-MS (DigiKey KC003T-ND)
- TM2 (optional) Keystone RL0503-55.36K-122-MS (DigiKey KC006T-ND)
- LS1 - Photonic Detectors (DigiKey PJDV-F5003-ND or PJDV-P8105-ND)
- SPKR - Sobotron GT-111P (DigiKey 422-1020-ND)
- Battery Clips - DigiKey BSPCF-ND (female) and BSPCH-ND (male), or BC9VPC-ND PC mount holder

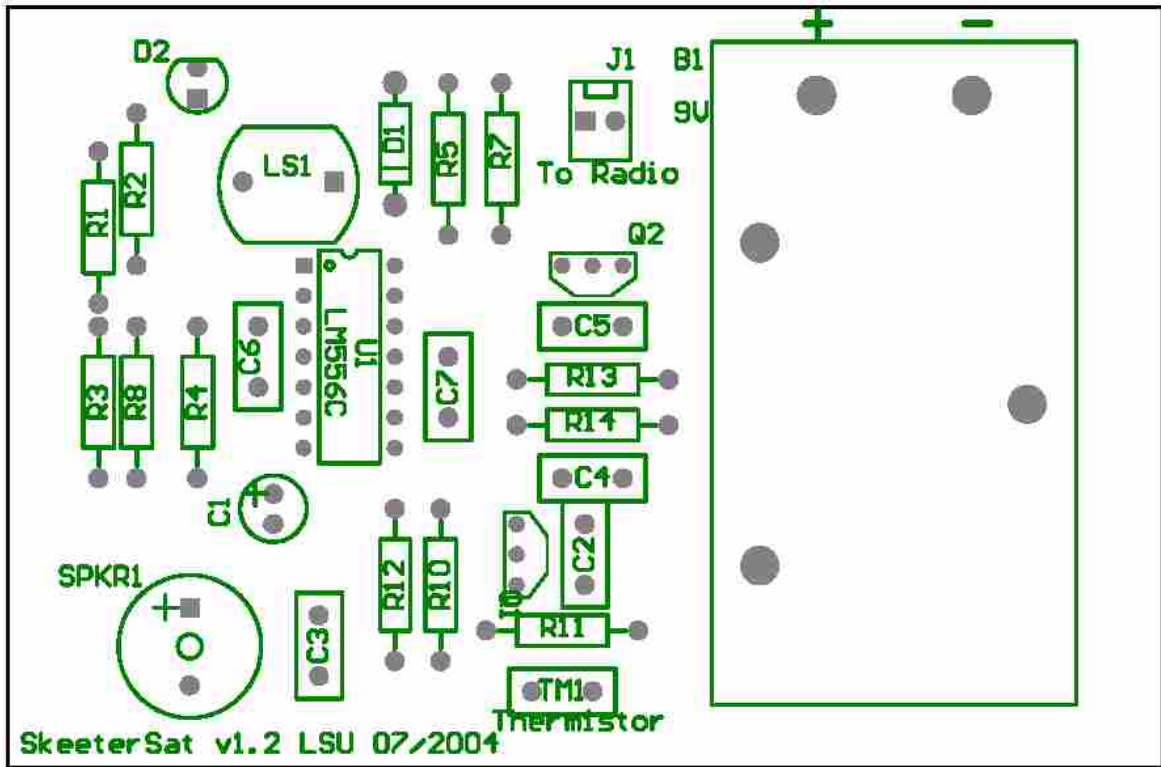

SkeeterSat component placement diagrams, silks screen (above) and copper (below)

