



HASP Payload Specification and Integration Plan

Payload Title: LunaSat Testbed

Payload Class: Small Large (circle one)

Flight Number: 2023-03

Institution: University of Colorado Boulder

Contact Name: Elsa Carreras

Contact Phone: 720-665-7387

Contact Email: elca6915@colorado.edu

Submit Date: 4/28/23

I. Mechanical Specifications:

- A. Measured weight of the payload in grams (not including payload plate): 2050.28g
(about 4.52 lb.)

Item	Mass (g)	Uncertainty (g)	Measured or Estimated
Raspberry pi zero x4	22.69		Measured
LunaSat x8	160.58		Measured
Insulation	30.00	5.00	Estimated
Aluminum 6061	1320.00	500.00	Estimated
Bolts x4	18.00		Measured
Washers x4	4.50	0.50	Estimated
White paint	2.00	0.50	Estimated
5V Buck converter	4.15		Measured
Real time clock x2	6.04		Measured
SD Card	0.52		Measured
3.3V Buck converter	4.793		Measured
Serial Adapter x8	23.09		Measured
I2C to RS-232 Adapter	2.07		Measured



HASP Payload Specification and Integration Plan

Protoboard	9.40		Measured
Wire x50	38.35		Measured
USB to mini-USB adapter (L-shaped) x2	19.01		Measured
USB to mini-USB adapter (straight) x6	114.534		Measured
USB hub x2	70.56		Measured
Misc	200		Estimated
	2050.28	506.00	

- B. Provide a mechanical drawing detailing the major components of your payload. Mechanical drawings detailing the attach points from the payloads to the payload plate are required.

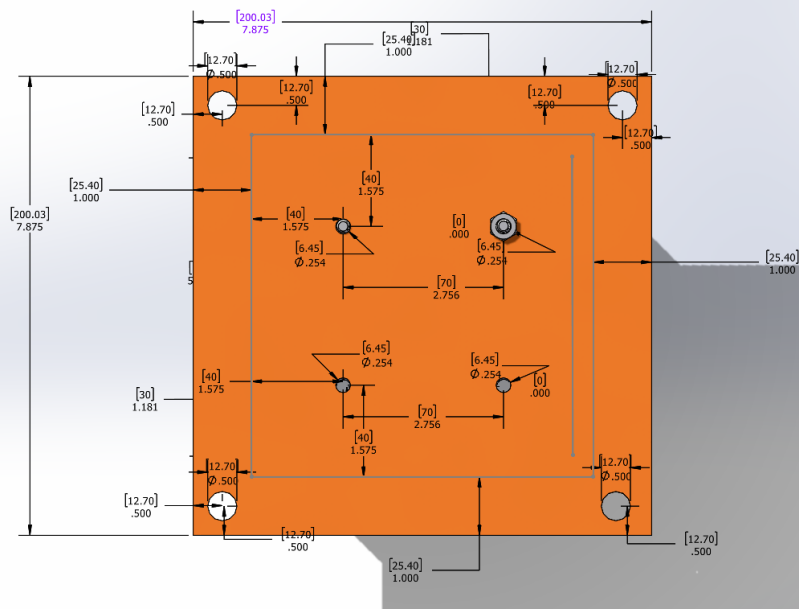

Figure 1: Bottom portion of the Payload attached to plate. Brackets are in millimeters



HASP Payload Specification and Integration Plan

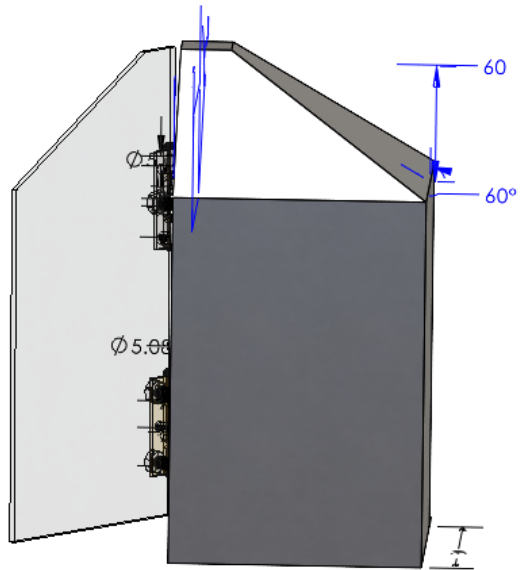

Figure 2: Payload view of door and exterior panels



HASP Payload Specification and Integration Plan

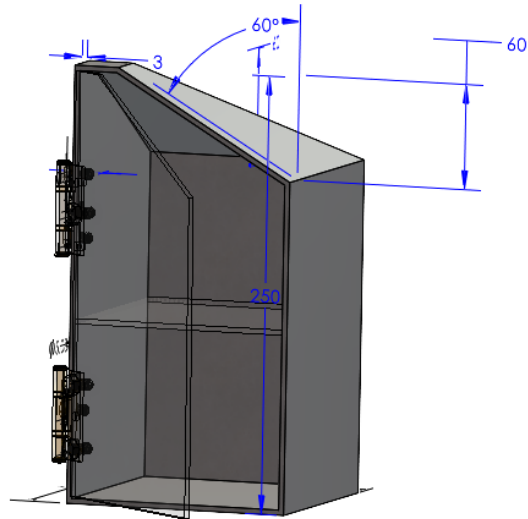

Figure 3: Payload with view of interior compartments

C. Other relevant mechanical information

The payload door operates by manual hinge, is snug fit but has a lock for extra security.

II. Power Specifications:

A. Measured current draw at 30 VDC: **0.153A**

Item	Voltage (V)	Current (mA)	Power (W)	Uncertainty (W)
2 Raspberry Pi Zero	5	700	3.5	0.25
7 HASP powered LunaSats	3.3	205	0.68	0.083
2 Real Time Clock – DS1307 RTC module	5	3	0.015	0

Commented [EC1]: Label the figure like in figure 1

Commented [VF2]: This exceeds the 500 mA limit we have right? why are we getting 150 mA instead?



HASP Payload Specification and Integration Plan

Total			4.19	0.33
-------	--	--	------	------

- Note: our team was having issues with measuring the power specifications of each individual component, however, we were able to set up the entire electrical system and measure the current draw of 0.153A.
- B. If HASP is providing power to your payload, provide a detailed power system wiring diagram starting from pins on the student payload interface plate EDAC 516 connector to all major components of your payload. All voltage lines must be labeled, and any power converters must be documented.

3.3V buck converter: SparkFun AP63203, 5V buck converter: SparkFun AP63357.

Commented [BH3]: Need to update this electrical schematic with the one in the CDR.

Commented [EC4]: This information needs to be moved either above the photo or below.

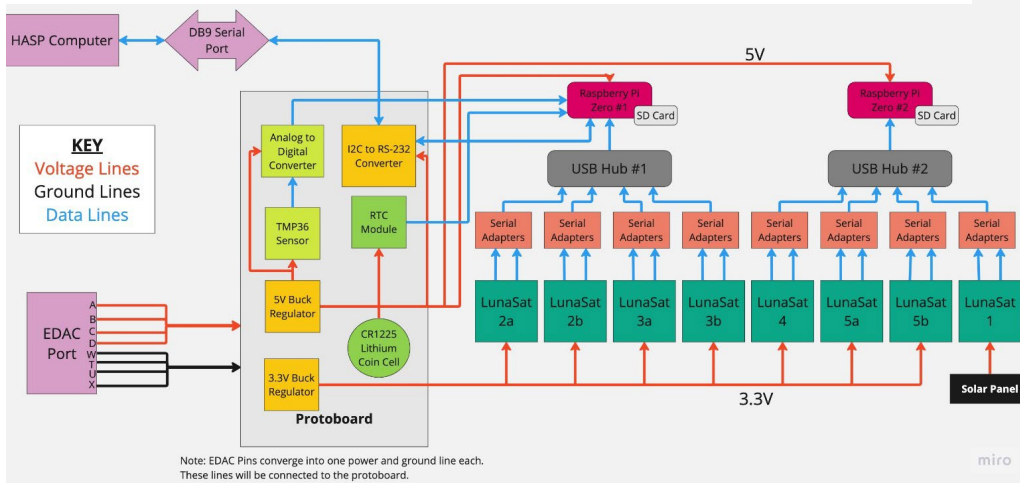

Figure: Electrical Schematic with Data and Major Components

C. Other relevant power information

There will be one LunaSat on the exterior of the payload that will be powered using solar power, with a total of three exterior LunaSats and five interior LunaSats. We will be using two Raspberry Pi Zero's, each handling the data of four LunaSats. All 8 of the LunaSats will be connected to the Raspberry Pi's using a FTDI breakout board and a USB hub. The LunaSats will communicate with the Raspberry Pi's using UART protocol. Other components such as the RTC module and the truth temperature sensor will communicate with the Raspberry Pi using I2C. The temperature truth sensor will be connected to an analog to digital converter which will be connected to the Raspberry Pi. The real-time clock module will also be connected to the

Commented [VF5]: It would be good to add here the information about the battery we intend to use, because it was not mentioned in our previous PSIP.

Commented [BH6R5]: Resolved

Commented [CB7]: Redone paragraph, not sure about the arduino microcontroller for the truth sensor or whether or not we're using the heating pad, I assumed not though

Commented [BH8R7]: Yes, that is correct. Thank you for the revision

Commented [BH9]: Only have temperature truth sensor now

Commented [EC10R9]: edited



HASP Payload Specification and Integration Plan

Raspberry Pi via I2C, providing a timestamp to all data so that we can maintain data organization in the case of power loss or a transmission error. Our clock will be powered by a 3V lithium coin cell battery which will allow for us to maintain real time through any power loss to the payload.

III. Downlink Telemetry Specifications:

- A. Serial data downlink format: **Stream** Packetized (circle one)
- B. Approximate serial downlink rate (in bits per second): 528
- C. Specify your serial data record including record length and information contained in each record byte. You must complete the table and include a sample data record.

Byte	Bits	Description
1-2	0-15	Institution name (CU)
3-8	0-47	Time (hhmmss)
9-10	0-15	Device ID (2A)
11-16	0-47	Temperature Reading (-10.99)
17-18	0-15	Device ID
19-24	0-47	Temperature Reading
25-26	0-15	Device ID
27-32	0-47	Temperature Reading
33-34	0-15	Device ID
35-40	0-47	Temperature Reading
41-42	0-15	Device ID
43-48	0-47	Temperature Reading
49-50	0-15	Device ID
51-56	0-47	Temperature Reading
57-58	0-15	Device ID
59-64	0-47	Temperature Reading
65-66	0-15	Device ID
67-72	0-47	Temperature Reading

* Note: our downlink data format will include 4 pieces of information: Institution name, timestamp, device ID, and temperature reading. We will be downlinking the ID and



HASP Payload Specification and Integration Plan

temperature reading of each LunaSat to monitor if its data collection and overall functionality are successful.

With all numbers represented in decimal format, displayed with spaces separating each value, and the institution name represented as ASCII text, an example packet might be:

```
6785 495053575357 5065 455053465757 5065 455053465757 5065 455053465757
5065 455053465757 5065 455053465757 5065 455053465757 5065 455053465757
5065 455053465757\n
```

- D. Number of analog channels being used: 0
- E. If analog channels are being used, what are they being used for?
- F. Number of discrete lines being used: 0
- G. If discrete lines are being used what are they being used for?
- H. Are there any on-board transmitters? If so, list the frequencies being used and the transmitted power.

Transmitter Model	Frequency	Transmitting Power
6 x active Semtech SX1272, used to verify RF communication between LunaSats (a component of the experiment) Note: These are not used for downlink and are part of the payload's experiment only.	915 MHz	6.3 mW peak, 0.5 mW average radiated power

Commented [VF11]: Is RF on continuously?

Commented [BH12R11]: Yes, after the 30 minute delay

- I. Other relevant downlink telemetry information. N/A

IV. Uplink Commanding Specifications:

- A. Command uplink capability required: **Yes** No (circle one)
- B. If so, will commands be uplinked in regular intervals: Yes **No** (circle one)
- C. How many commands do you expect to uplink during the flight (can be an absolute number or a rate, i.e. *n commands per hour*): Our payload is designed to operate autonomously, and will not require regular uplink serial commanding. Uplink serial commanding will only be used on the occasion of a contingency.
- D. Provide a table of all uplink commands for your payload

Commented [BH13]: Talk to Zack, as the on/off command will have nothing to do with our own uplink capabilities. Other than that, we will likely not have enough time to implement uplink.



HASP Payload Specification and Integration Plan

Command Name	2-Byte Command (Hex Format)	Command Description
Reboot Flight Computer	0xAA 0x01	Reboots the Raspberry Pi Zero
Ping Flight Computer	0xBA 0x00	Results in the flight computer returning a confirmation packet over downlink

E. Are there any on-board receivers? If so, list the frequencies being used.

915 Mhz is used for the on-board RF experiment.

F. Other relevant uplink commanding information.

The "Ping Flight Computer" command will result in a "YES" if successful, indicating that our computer is responsive and operational.

V. Integration and Logistics

A. Date and Time of your arrival for integration: 4/23/23 at 8:00 am

B. Approximate amount of time required for integration: 15 minutes

C. Name of the integration team leader: Ben Hellem

D. Email address of the integration team leader: Behe8000@colorado.edu

E. List **ALL** integration participants (first and last names) who may be present for integration with their email addresses:

Name	E-Mail Address	Phone Number
Benjamin Hellem	behe8000@colorado.edu	(719)-659-3764
Elsa Carreras	elca6915@colorado.edu	(720)-665-7387
Erick Bueno	quu.ebc@gmail.com	(719)-639-4714
Chloe Zentner	chze3627@colorado.edu	916-764-7389

F. Define a successful integration of your payload:

- i. Payload is mounted onto the HASP platform
- ii. Payload is receiving power
- iii. Data collection is successful
- iv. Downlink capabilities are successful
- v. Uplink capabilities are successful
- vi. Structural integrity is maintained

G. List all expected integration steps:



HASP Payload Specification and Integration Plan

- i. Place payload (already attached to payload plate) over the mounting location on the platform.
 - ii. Secure the plate to the platform by bolting the 4 corners of the plate to the platform.
 - iii. Connect the EDAC to the HASP platform.
 - iv. Verify that the LED on the electrical components is lit, signaling that the components are receiving power.
 - v. Run the payload for five minutes so that data is read to the Raspberry Pi SD card from the LunaSats.
 - vi. Connect DB9 cable to payload plate and connect to computer to verify that data downlink is successful.
 - vii. Send both uplink commands through the serial connection to verify that uplink commanding is successful.
 - viii. Inspect the structure for any damage sustained during integration to evaluate its structural integrity.
- H. List all checks that will determine a successful integration:
- i. The payload is secured to the platform tightly.
 - ii. EDAC is connected and provides power to the payload.
 - iii. LED blink indicates power to electrical components.
 - iv. Data is written onto the Raspberry Pi's SD card.
 - v. Payload is able to downlink data through the DB9 serial port.
 - vi. Payload received and executed uplink commands.
 - vii. Payload maintains its structural integrity.
- I. List any additional LSU personnel support needed for a successful integration other than directly related to the HASP integration (i.e., lifting, moving equipment, hotel information/arrangements, any special delivery needs...):
- i. Not applicable
- J. List any LSU supplied equipment that may be needed for a successful integration:
- i. Not applicable

VI. Hazards

- A. Are you flying anything that is potentially hazardous, as listed in the Call for Proposal and the HASP Student Manual, to HASP or the ground crew before or after launch:



HASP Payload Specification and Integration Plan

B. Yes No (Circle one)



HASP Payload Specification and Integration Plan

Appendix A: NASA Hazard Tables

If you intend to fly a listed hazard on HASP, you must **fully complete** the appropriate hazard form and include the form on **both** the Preliminary PSIP and the Final PSIP. This documentation is required for NASA safety to clear your payload for flight. Be specific and as detailed as possible with the information requested.

Appendix A.1 Radio Frequency Transmitter Hazard Documentation

HASP 2022 RF System Documentation	
Manufacture Model	Semtech
Part Number	SX1272
Ground or Flight Transmitter	Flight
Type of Emission	Spread Spectrum
Transmit Frequency (MHz)	915
Receive Frequency (MHz)	915
Antenna Type	TI SWRA416, Miniature helical PCB antenna
Gain (dBi)	0.01 dBi expected from reference designs. Preliminary measurements read approx -10 dB.
Peak Radiated Power (Watts)	0.01 dBm (1 mW) expected from reference designs. Current assumptions (+18 dBm transceiver output) and preliminary measurements (-10 dB "gain") predict 6.3 mW peak power.
Average Radiated Power (Watts)	-2.61 dBm (0.5 mW) expected from reference designs.



HASP Payload Specification and Integration Plan

Appendix A.2 High Voltage Hazard Documentation

HASP 2022 High Voltage System Documentation	
Manufacture Model	N/A
Part Number	N/A
Location of Voltage Source	N/A
Fully Enclosed (Yes/No)	N/A
Is High Voltage source Potted?	N/A
Output Voltage	N/A
Power (W)	N/A
Peak Current (A)	N/A
Run Current (A)	N/A



HASP Payload Specification and Integration Plan

Appendix A.3 Laser Hazard Documentation

HASP 2022 Laser System Documentation			
Manufacture Model		N/A	
Part Number		N/A	
Serial Number		N/A	
GDFC ECN Number		N/A	
Laser Medium		N/A	
Type of Laser		N/A	
Laser Class		N/A	
NOHD (Nominal Ocular Hazard Distance)		N/A	
Laser Wavelength		N/A	
Wave Type		N/A (<i>Continuous Wave, Single Pulsed, Multiple Pulsed</i>)	
Interlocks		N/A (<i>None, Fallible, Fail-Safe</i>)	
Beam Shape		N/A (<i>Circular, Elliptical, Rectangular</i>)	
Beam Diameter (mm)	N/A	Beam Divergence (mrad)	N/A
Diameter at Waist (mm)	N/A	Aperture to Waist Divergence (cm)	N/A
Major Axis Dimension (mm)	N/A	Major Divergence (mrad)	N/A
Minor Axis Dimension (mm)	N/A	Minor Divergence (mrad)	N/A
Pulse Width (sec)	N/A	PRF (Hz)	N/A
Energy (Joules)	N/A	Average Power (W)	N/A
Gaussian Coupled (e-1, e-2)		N/A (<i>e-1, e-2</i>)	
Single Mode Fiber Diameter		N/A	
Multi-Mode Fiber Numerical Aperture (NA)		N/A	
Flight Use or Ground Testing Use?		N/A	



HASP Payload Specification and Integration Plan

Appendix A.5 Battery Hazard Documentation

Commented [VF14]: Make sure this table is filled out with the battery info. Also check the electrical diagram, it needs to reflect the use of the battery for the RTC.

Commented [BH15R14]: Resolved

HASP 2022 Battery Hazard Documentation	
Battery Manufacturer	Grainger
Battery Type	CR1225 3V Lithium coin cell
Chemical Makeup	Lithium Manganese Dioxide (Li-MnO ₂)
Battery modifications	NO
UL Certification for Li-Ion	N/A
SDS from manufacturer	ANSI-OSHA
Product information sheet from manufacturer	http://complyplus.grainger.com/granger/msds.asp?sheetid=4213651