



# HASP Student Payload Application for 2018

Payload Title: SORA 2.0 – Stratospheric Organisms and Radiation Analyzer		
Institution: University of Houston		
Payload Class: <b>LARGE</b>		Submit Date: December 15 <sup>th</sup> , 2017
<p>Project Abstract:</p> <p>The SORA 2.0 payload will again sample for the existence of microorganisms and bacterial spores in the upper atmosphere. This mission will build upon the first SORA mission in 2017, and help confirm previous findings using a further developed capture system. Furthermore, the payload will study various aspects of the surrounding environment such as radiation exposure, temperature, pressure and humidity. The payload has three main scientific objectives. First, build upon and further develop a novel system<sup>[1]</sup> that will isolate surrounding air and sample for cells. Second, an on-board MiniPIX USB<sup>[2]</sup> silicon sensor will analyze exposure to cosmic radiation that microorganisms may encounter. Finally, a mature version of RESU (Realtime Environmental Sensing Unit)<sup>[1]</sup> will monitor the environmental conditions such as temperature, pressure, and humidity. The payload design will take advantage of additive manufacturing and hobby electronics in its construction to provide an accessible basis for future missions and explore the bounds of the technology available.</p>		
Team Name: University of Houston		Team or Project Website: www.soraone.us
Student Leader Contact Information:		Faculty Advisor Contact Information:
Name:	Samuel A. Garcia Morelos	Dr. Andrew Renshaw
Department:	Physics	Physics
Mailing Address:	25915 Pepper Bend Lane	University of Houston Office: SR1 406B
City, State, Zip code:	Katy, TX 77494	Houston, TX 77204
e-mail:	samuel.morelos@gmail.com	arensaw@central.uh.edu
Office Telephone:	N/A	(713)-743-0925
Mobile Telephone:	(502)-649-5995	(909)-721-3970

## SORA 2.0: Stratospheric Organism and Radiation Analyzer

S. A. Garcia Morelos,<sup>1</sup> F. Brooks,<sup>1</sup> S. Oliver,<sup>1</sup> A. Walker,<sup>1</sup> K. D. Portillo,<sup>1</sup>  
R. B. Masek,<sup>1</sup> S. George,<sup>1</sup> D. Pattison,<sup>1</sup> and A. L. Renshaw<sup>1</sup>

<sup>1</sup>*Department of Physics, University of Houston, Houston, TX 77204, USA*

### Abstract

The SORA 2.0 payload will again sample for the existence of microorganisms and bacterial spores in the upper atmosphere. This mission will build upon the first SORA mission in 2017, and help confirm previous findings using a further developed capture system. Furthermore, the payload will study different aspects of the surrounding environment such as radiation exposure, temperature, pressure and humidity. The payload has three main scientific objectives. First, build upon and further develop a novel system [1] that will isolate surrounding air and sample for cells. Second, an on-board MiniPIX USB silicon sensor [2] will analyze exposure to cosmic radiation that microorganisms may encounter. Finally, a mature version of RESU (Realtime Environmental Sensing Unit) [1] will monitor the environmental conditions such as temperature, pressure, and humidity. The payload design will take advantage of additive manufacturing and hobby electronics in its construction to provide an accessible basis for future missions and explore the bounds of the technology available.

## CONTENTS

1. Mission Statement and Objectives	1
1.1. Hypothesis and Objectives	2
2. Background	2
2.1. Astrobiology	2
2.2. Radiation	2
3. Payload Systems and Operation	3
3.1. RESU Design	3
3.1.1. Overview	3
3.1.2. The Sensors	4
3.1.3. Space Constraints	5
3.2. Astrobiology System	5
3.2.1. Design and Operation	5
3.2.2. Pre-Flight Preparation	5
3.2.3. Post-Flight Procedures	6
3.3. Radiation Monitoring System	7
3.3.1. MiniPIX Detector	7
3.3.2. Calibration	8
3.3.3. Collection Parameters	8
3.3.4. Data Format	8
4. HASP Interface	9
4.1. Interfacing with HASP: Serial Uplink and Downlink	9
4.2. Interfacing with HASP: EDAC and DB9 Connections	9
4.3. Interfacing with HASP: Serial Downlink	9
5. Thermal Control Plan	10
6. Power and Weight Budget	11
7. Procedures	11
7.1. Decontamination	11
7.1.1. Objectives	11
7.1.2. Sterilization Preflight	11
7.1.3. Sterilization Post flight	12
7.2. Testing	12
7.2.1. Vacuum Chamber	12

7.3. Integration Procedures	12
7.3.1. Houston Integration	12
7.3.2. HASP Integration	13
7.3.3. Post Integration Operations	13
7.4. Flight Operations	13
7.5. Post-Flight Operations	13
8. In-Flight Failure Contingency Plan	14
9. Project Management	14
9.1. Team Structure	14
9.2. Roles and Responsibilities	14
9.3. Timeline	17
9.4. Funding	17
References	18

# HASP Payload Application 2018

## 1. MISSION STATEMENT AND OBJECTIVES

Our goal for the HASP 2018 payload is to further build upon the first SORA [1] flight. In order to confirm our findings from SORA 2017, we need to again collect extremophile bacteria that reside in the upper atmosphere at approximately 36 to 41 kilometers. A MiniPIX particle detector will be flown onboard to further study the effects of ionizing radiation on these living organisms and other various sensors will gather data pertaining to the environmental conditions in which these extremophiles reside. Due to the limited amount of data for the 20 to 40 kilometer altitude range, we have generated questions, hypotheses and objectives, based on past HASP payloads and other high altitude collection flights, that have thus far remained unanswered or have little corroborating data.

The main goals for SORA are to collect extremophile organisms that reside in the upper atmosphere, study the effects of surrounding radiation on these organisms in the stratosphere and gather data pertaining to the environmental conditions in which these organisms reside [1]. More specifically, SORA has two sets of main objectives, along with four additional objectives.

### **Primary Scientific Objectives:**

1. Attempt to capture microorganisms in the upper atmosphere at approximately 30 km to 41 km of altitude using multiple methods.
2. Culture samples and compare the collection medium.
3. Study the cosmic and terrestrial radiation in which these extremophiles may reside.

### **Secondary Scientific Objectives:**

1. Test RESU further and develop a more power-efficient flight control system.
2. Determine the polar angle of hits on the detector, compare them to payload orientation information and develop simulations to verify the results.
3. Further testing of the astrobiology hardware in flight and the methodology for collection of microbes in extreme environments at high-altitude.
4. Improve pre-and post-flight decontamination procedures.

### **Engineering Objectives**

1. Implement a variable shutter time for the MiniPIX based on the flux of particles incident on the detector.
2. Analyze MiniPIX data in real time and downlink relevant radiation statistics.
3. Implement a redundant data storage mechanism.
4. Test an improved enclosure against impacts and harsh environments.
5. Improve astrobiology collection mechanism.

These goals and objectives are based on the following scientific questions: After confirming that microorganisms are present in the upper atmosphere in our last mission [1], what extremophiles are present in the upper atmosphere at altitudes of 36 to 41 km? If extremophiles are captured, can we culture the microorganisms? What methods are more effective at capturing bacteria for culturing? Finally, with a deeper understanding of the MiniPIX after our first mission, can we collect more data to study cosmic radiation that microorganisms and spores are exposed to on a daily basis? Specifically, can we obtain useful information about the biological effectiveness of this radiation on bacteria through parameters such as linear energy transfer and dose equivalent?

# HASP Payload Application 2018

## 1.1. Hypothesis and Objectives

1. Based on the collection results from previous missions such as SORA [1], we predict the concentration of cells at an altitude of 36 km will be less than 500 cells per liter [3].
  - (a) Objective: Sample a minimum volumetric amount of air at target altitude for the duration of the float phase (approximately 15 to 18 hours).
2. Based on control samples and testing before flight, we can compare our final flight results to previous applications.
  - (a) Objective: Quantify and characterize any contamination with our laboratory and payload disinfection procedures.
  - (b) Objective: Minimize the amount of external contamination before flight with thorough decontamination procedures.
3. Based on measured results of dosage rates, the higher exposure to radiation may change the organism's cellular make-up.
  - (a) Objective: Quantify the intensity and exposure of cosmic radiation for the duration of the flight.
  - (b) Objective: After capturing samples, analyze data and compare biological effects to similar genotypes found on Earth's surface.

## 2. BACKGROUND

### 2.1. Astrobiology

Extremophiles thrive in physically and/or chemically extreme conditions, which are detrimental to most of life on Earth as we know it. These organisms and microbes have been found everywhere, from deep underwater volcano vents to buried ice lakes in Antarctica [4]. As shown in Table I, fungi and bacterial spores have previously been found in the stratosphere. Arguably, each successful collection expedition of at least 30 km into the upper atmosphere provides information that could be useful in determining what life forms can exist inside and outside of Earth's biosphere. Today, the most common altitude for bacterial collection in the atmosphere occurs in the range of approximately 10 km to 20 km above Earth's surface; very little data exists on microbiological samples captured in the stratosphere. Conditions at altitudes of 30 km to 40 km are extreme in temperature, pressure and radiation.

Our experiment is an attempt to further develop our technique for capturing microorganisms in the upper atmosphere, as demonstrated during our 2017 [1] flight; which was inspired by the LSU HASP 2011, 2012, 2013 flights [3] and from research by D.R. Canales [5]. This flight will help confirm the results from our first flight and potentially enable us to culture these rare microorganisms. We will use two of the KNF N84-4 commercial gas-sampling diaphragm vacuum pumps to sample the air at approximately 33 km above Earth's surface. The samples we hope to collect are an important part to expanding our understanding of Earth's biosphere. Further studies could provide more insight on how life can be distributed on Earth, and ultimately, through outer-space.

### 2.2. Radiation

The study of the biological effects of cosmic radiation in space or in the atmosphere is important for human space travel. Long term space travel necessarily requires humans and other biological specimens to be exposed to high levels of radiation for extended periods of time, so understanding the amount of radiation exposure experienced from galactic cosmic rays (GCRs) has important applications for flights to Mars and beyond. Also, the understanding of cosmic rays specifically in Earth's atmosphere has important

# HASP Payload Application 2018

TABLE I. History of Microbiological Sampling of the stratosphere [1].

Date	Altitude (km)	Sample Method	Biology Measured	Volume
1936	11 - 12	Balloon	5 Bacillus sp., 1 Penicillium sp., 1 Macrosporium sp., 2 Aspergillus sp.	<i>Unknown</i>
1978	48 - 77	Meteorological Rocket	Mycobacterium sp., Mircococcus sp.	<i>Unknown</i>
2003	30 - 41	Balloon, liquid neon cryopump	Isolated <i>S. pastuerii</i> , <i>B. simplex</i> , the fungus, <i>Egyndontium album</i>	57
2004	20	Airplane, Impactor Surfaces	<i>Bacillus luciferins</i> , <i>Bacillus sphaericus</i>	<i>Unknown</i>
2006	19 - 41	Balloon, Liquid Neon Cryopump	7 cells L-1 (counting clumps), <i>Bacillus</i> sp., <i>Staphylococcus</i> sp., <i>Engyodontium</i> sp.	19 – 81
2007	20	Airplane, Impactor Surfaces	Micrococci, Microbacteria, <i>Staphylococcus</i> sp., <i>Brevibacterium</i> sp.	<i>Unknown</i>
2010	20	Airplane, Impactor Surfaces	Isolated <i>Bacillus</i> sp.	<i>Unknown</i>
2017	32	Balloon, liquid medium and vacuum pump	Multiple findings [1]	<i>Unknown</i>

applications to commercial airplane flights as they generally operate at an altitude with far higher levels of radiation exposure than at the surface of Earth.

Our goals for the radiation portion of our payload are two fold: to measure radiation levels at various layers in the atmosphere to determine its possible effects on microorganisms, and to use a MiniPIX particle detector to gather data from GCRs in the atmosphere. Using the results from the previous iteration of SORA [1] as a baseline, we know the capabilities of the MiniPIX, and we will make several design changes to improve the efficiency of our system and to produce more in-depth data analysis. We ultimately seek to further previous research utilizing MediPIX/TimePIX devices for measuring GCRs on stratospheric balloon flights [6].

### 3. PAYLOAD SYSTEMS AND OPERATION

The SORA 2.0 payload will have an upgraded and more efficient flight computer, a fully developed astrobiology system and a MiniPIX USB silicon-based hybrid-chip particle detector. The astrobiology system will build upon the previous mission, but this time we are seeking to capture and culture any microorganisms we may find. Our previous mission in 2017 confirmed that our astrobiology system functions well beyond expectations and that there are microorganisms in the upper atmosphere.

#### 3.1. RESU Design

##### 3.1.1. Overview

For this mission, we will again use RESU (Real-Time Environmental Sensing Unit), our flight computer to manage flight operations and send and receive commands from the ground. RESU is composed of two components: a Raspberry Pi 3 (RP3) and an Arduino Mega (Arduino) which interface via USB. The RESUs primary purpose during the flight will be to monitor environmental conditions and control the astrobiology systems. It will monitor temperature of the various subsystems and the humidity and pressure of the environment throughout the flight. All recorded data will continuously be written to an SD card mounted on a shield on top of the Arduino. It will also accept discrete commands from the HASP systems to turn the astrobiology collection system on and off.

During our last flight we only had one mechanism for storing data with no redundancy. This means that if one of our storage devices had been damaged or corrupted during flight, all of our data would have been lost. In order to harden our payload and ensure the safety of our data we will now store redundant copies of our data. One will be stored on the SD card directly on the Arduino and the other will be transferred to

# HASP Payload Application 2018

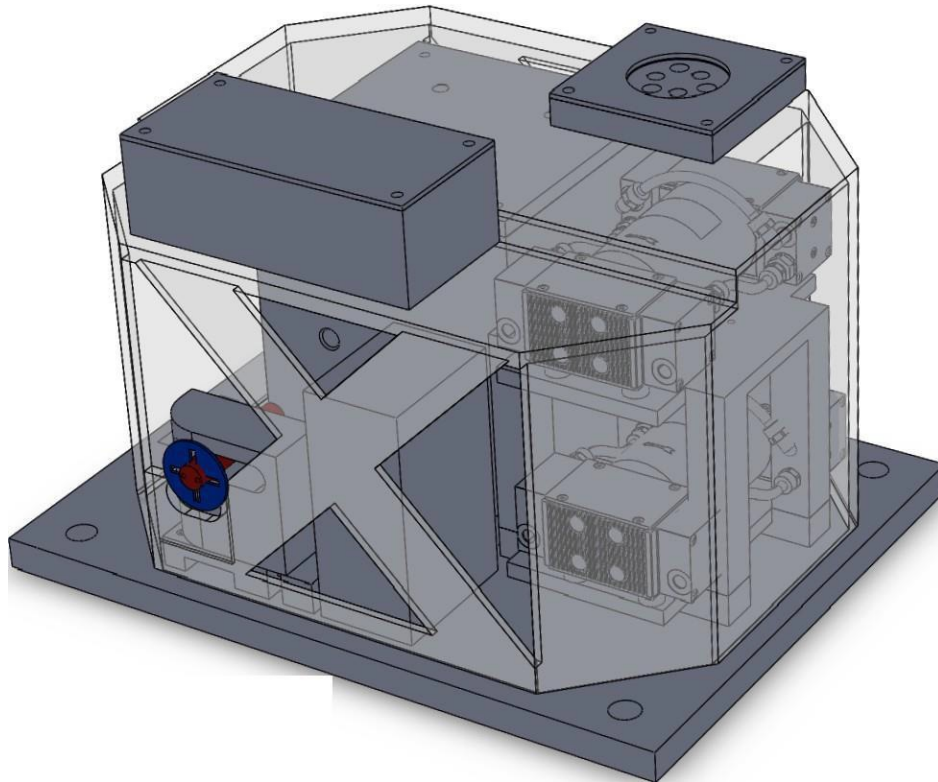

FIG. 1. SolidWorks 3D CAD design of the SORA payload.

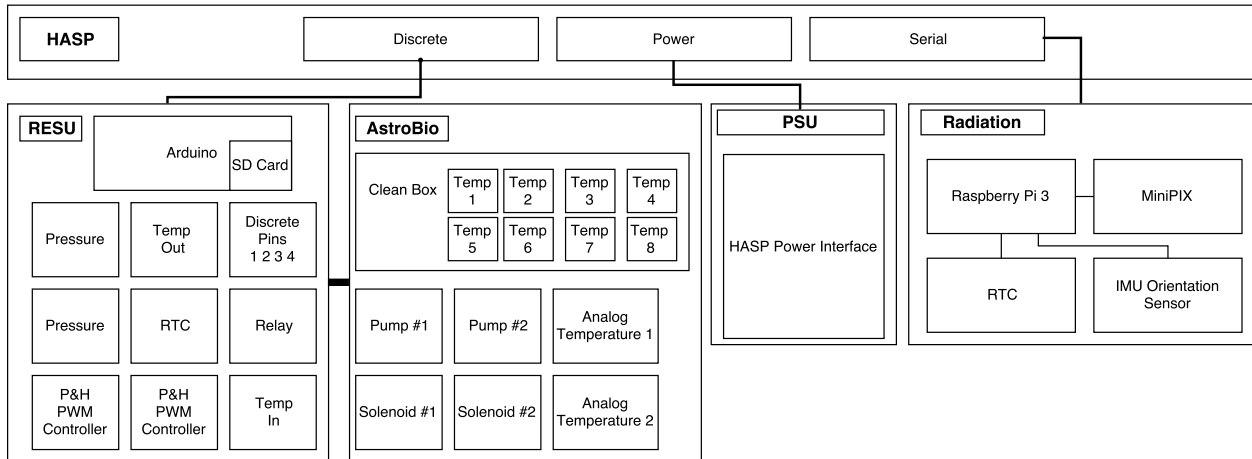

FIG. 2. Abstract subsystem design for SORA 2.0.

the RP3 for storage.

### 3.1.2. The Sensors

Our payload will utilize eight thermistors to measure temperature at various points in our payload. The decision to use thermistors was based primarily on the performance of the analog temperature sensors during our 2017 flight, during which several of those sensors had slight malfunctions. Thermistors are able



# HASP Payload Application 2018

to accurately measure temperature in the range  $-55^{\circ}\text{C}$  to  $125^{\circ}\text{C}$  and should therefore be adequate for the conditions in the stratosphere. Pressure will be recorded from two identical digital pressure sensors in order to ensure accuracy and should be able to record accurately in the range 0 mbar to 14 000 mbar. Finally, humidity will be measured from a basic analog humidity sensor. All sensor data will be UTC timestamped via the onboard real time clock and recorded to the SD card.

TABLE II. Table of sensors that compose RESU

Sensor	Quantity	Platform	Purpose
Temperature Sensors	6	Arduino	Record temperature measurements
Pressure	2	Arduino	Record pressure measurements
Inertial Measurement Unit	1	RP3	Record IMU Data in 9 degrees of freedom
Real Time Clock	2	Arduino/RP3	Record temperature compensated timestamps in CT
Humidity	1	Arduino	Record atmospheric humidity levels
MiniPIX	1	RP3	Cosmic ray detector

### 3.1.3. Space Constraints

Since much of the space inside of our payload will be taken up by the pumps and clean box from the astrobiology systems, we need to design our electronics to be relatively compact. We will again only use one RP3 to both interface with MiniPIX and store sensor data from the Arduino. Also, in order to reduce the space required for the interface between the Arduino and all of the payload's sensors, we will use two layers of proto-shields to more effectively utilize vertical space. The RTC, pressure and humidity sensors will be mounted directly on the first shield while the temperature sensors will be mounted on the top most shield.

## 3.2. Astrobiology System

### 3.2.1. Design and Operation

The collection assembly will be designed as a multi-compartment structure, with various collection and control containers, two pumps, two pump heaters, and two solenoids. The control containers will be connected to a solenoid that will remain closed until post-sanitation procedures are performed. The sample collection containers will be connected to a vacuum pump located outside of the clean box structure. One of the chambers will be a non-liquid collection container. Heaters will be attached to the pumps to aid during a cold start. Once float altitude is reached, the solenoids connected to the sample collection containers will be opened and the pumps will be powered on; allowing air to flow to the collection containers. The containers will hold a range of amounts and concentrations, 30 mL to 60 mL of 15 % to 30 % sterile glycerol solutions. A 316 Stainless Steel 1/4" NPT Vent to Atmosphere Vitron Seal Valve will be embedded in each of the compartments, to accommodate for the pressure changes that occurs with the variations in altitude over the course of a flight [7]. The left side of Figure 3 displays the collection assembly with the openings for the sample and exhaust tubing, while the right side of Figure 3 shows the 3D rendering of the sampling pump.

### 3.2.2. Pre-Flight Preparation

The clean box, collection containers and tubing will be autoclaved. All tools used in the assembly of the clean box will either be autoclaved or soaked in a 70 % ethanol solution inside of a clean room. Each person who enters the clean room will be garbed in a lab coat, goggles, hair net and latex gloves after thoroughly washing their hands in a 70 % ethanol solution.

## HASP Payload Application 2018

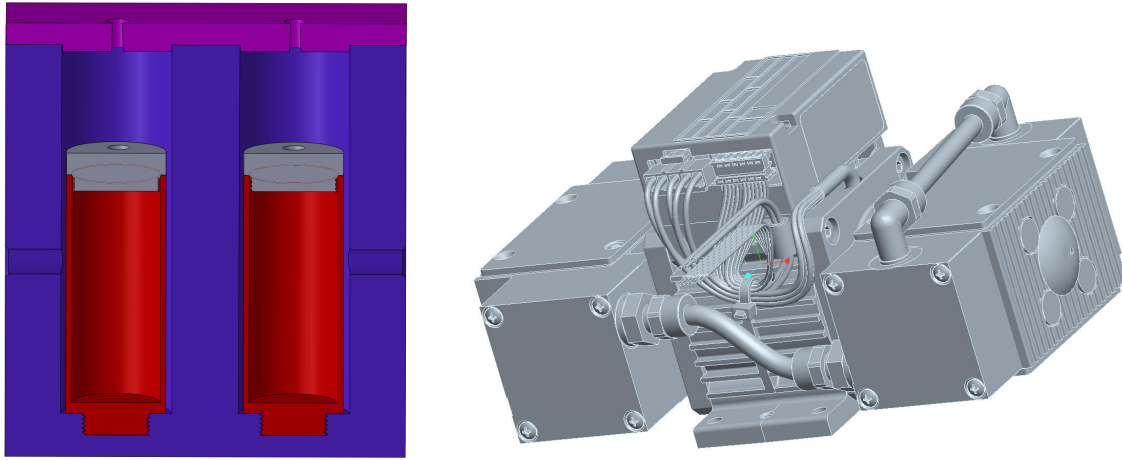

FIG. 3. **Left:** Cross-section view of the clean box with experimental and control containers. **Right:** KNF N84-4 commercial gas-sampling diaphragm vacuum pump.

We will vary the glycerol concentration and increase the amount of medium within the assembly. The 15 %, 25 %, and 30 % glycerol solutions will be poured into each container, the lid will then be sealed with silicone gasket maker along with the tubing inserted and gasket sealed into the container lids. Each lid will have two holes, one that leads to the inside of the clean box to allow for pressure to be released from inside the container and outgassed through the valve that will be embedded in the box, while the other hole will be passed through the clean box lid to allow the tubing to connect to the pump - solenoid system only in the case of the control tubing. The lid to the clean box will be sealed with silicone gasket maker, the box will be mounted onto the payload and the tube from the control container will be clamped to the dedicated control solenoid, while the sample collecting tube will be passed through the other solenoid and connect to the pump. A final piece of tubing will be connected from the intake valve on the pumps to the outside of the payload, after a 70 % ethanol solution is ran through the pump several times. The end of the tubing will connect to a mechanism that will isolate the inner tubing until float conditions are reached. The payload will then be closed and remain in the clean room until it is ready for transport flight.

### 3.2.3. Post-Flight Procedures

Once the payload is retrieved, the intact clean box needs to be removed and placed inside of a cooler with ice to be then transported to The University of Houston and placed in cold storage at 4 °C. All equipment used in the filtration process will be either autoclaved or taken from previously unopened sanitized packaging. The autoclaved, pre-sanitized items and the clean box will then be washed in a 70 % ethanol solution before they are placed inside a SterilGARD e3 Class II Biological Safety Cabinet (the Cabinet). The cabinet has a laminar flow air barrier and UV lights built into the ceiling for decontaminating the workspace prior to use. A portion of both the control and sample collection solutions will be vacuum filtered through a Fluoropore membrane filter (13 mm; 0.22 micron) to collect specimens on the filter surface. The filters will then be packaged for in-house 16S ribosomal RNA sequencing. In addition, the remaining portion of the glycerol solutions will be used on various culturing media in an attempt to culture any microbes that are collected.

# HASP Payload Application 2018

## 3.3. Radiation Monitoring System

### 3.3.1. MiniPIX Detector

The MiniPIX detector, shown in Figure 4 is a silicon-based hybrid pixel detector built by ADVACAM [8] that utilizes technology developed by the MediPIX2 collaboration at CERN [9]. The sensor is composed of a pixellated silicon sensor integrated with a single TimePIX readout chip (256 x 256) pixels with a pitch of 55  $\mu\text{m}$ , the layers of the detector are shown in Figure 5. The sensor is 500  $\mu\text{m}$  thick and uses a USB 2.0 interface with a readout rate up to 30 frames per second. Each pixel can be programmed to work in one of three modes: Single particle counting, Time-over-Threshold (TOT), or Time-of-Arrival (TOA). This device offers a variety of applications including X-ray and neutron imaging as well as particle identification by characterizing each particle due to their charge, energy, and direction.



FIG. 4. Picture of a MiniPIX particle detector [8].

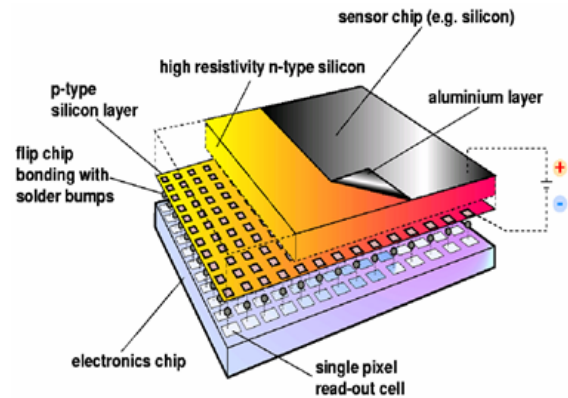

FIG. 5. Hybrid pixel detector silicon sensor [2].

The MiniPIX registers ionized particles when the active material in the detector is transformed into a charge (the excitation of electron-hole pairs in the semiconductor). When these charges are collected, the Si bulk is then depleted by an applied bias voltage, which occurs when the electronics reads-out electron-hole pairs. If these pairs are above the threshold when collected by the pixel electronics, the count increases. The projection of the deposited charge is measured and the total energy deposited can be determined from the back-plane pulse amplitude.

When a particle is incident on the sensor, a particle track is produced along the path length through the sensor area. The path of a single particle through the sensor is called the particle track. Each particle track may be identified as a “cluster” or continuous area of neighboring pixels in a given frame. Each individual cluster can be differentiated through statistical analysis to describe the shape and energy deposition, allowing us to distinguish between different types of radiation by organizing each cluster into aspecific morphological category.

The primary purpose of the MiniPIX is to detect four specific types of radiation: alpha ( $\alpha$ ), electron ( $e^-$ ), gamma ( $\gamma$ ), and muon ( $\mu$ ). By comparing the results of the flight to results obtained from simulations, an estimate regarding the percent composition of the detector hits can be made.

The MiniPIX case and heat sink assembly shown in Figure 6 is designed to protect the device from any moisture in the atmosphere. The case and lid will be 3D printed using ABS plastic and the heat sink will be composed of two large sheets and a small block of aluminum metal which will all be mounted to the roof of the payload. Thermal paste will be applied at every contact point between the device and each of the aluminum pieces to allow for optimal thermal conduction and radiation of heat away from the MiniPIX. A picture of the MiniPIX device inside the case and heat sink assembly used on SORA 1.0 is shown in Figure 7. Considering the success of that setup, we will mimic a similar configuration on SORA 2.0.

# HASP Payload Application 2018

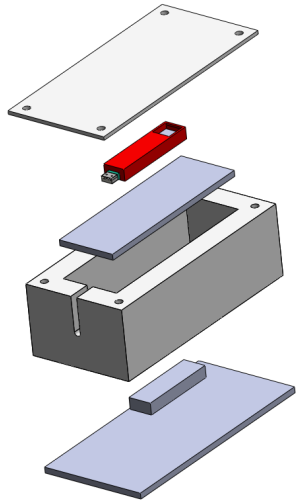

FIG. 6. 3D rendering of the MiniPIX case and heat sink assembly.



FIG. 7. Picture of the MiniPIX mounted in the case and heat sink assembly on SORA 1.0.

### 3.3.2. Calibration

The appropriate calibration of the MiniPIX detector will be applied at The University of Houston by Dr. Stuart P. George, a collaborator within the MediPIX Collaboration. The source calibration will be applied using the 60 keV  $^{241}\text{Am}$  decay line, Sn Fluorescence and  $^{55}\text{Fe}$  gamma rays. The TimePIX hybrid pixel detector consists of 65 536 silicon p-n diodes, with each containing its own individual processing circuit. The response of each pixel can never be identical, thus a calibration must be performed for each individual pixel. Dr. George will calibrate the pixel energy threshold from DAC counts to energy [10]. The threshold will be set at 4 keV, just above the noise level of the detector. The set threshold energy of the TimePIX chip determines what energies of particles are allowed to be measured by the detector. Energy measurements in the detector are accounted by measuring the charge collected in each individual pixel. The sensor's bias voltage will be 200 V to ensure that the sensor was completely depleted.

### 3.3.3. Collection Parameters

### 3.3.4. Data Format

The data format for each frame of data is a plain text array with each value corresponding to the value at the corresponding pixel index in the detector. Upon the capture of a new frame the plain text array will be appended to the acquisition file stored on the SD card of the RP3 on our payload. In a separate file various metadata will be stored for each frame including the detector threshold, acquisition time, acquisition mode etc. The plaintext array format means that each frame of data utilized approximately 132 kB of memory. In SORA 1.0, a frame was saved roughly every six seconds, over the course of the roughly fourteen hour flight we had a total acquisition size of approximately 1.1 GB. While this was a rather small total collection size, we could have further reduced our memory footprint by only storing pixel indices with non-zero time over threshold values i.e. storing data in a sparse matrix format. This is a route we will look into for SORA 2.0.

# HASP Payload Application 2018

## 4. HASP INTERFACE

### 4.1. Interfacing with HASP: Serial Uplink and Downlink

During the duration of our flight the serial uplink commands will be used to configure the collection parameters of the MiniPIX radiation detector. When a command is received from the mission control team, it will be transmitted straight through the DB9 connection into the RPI3 through an RS232 to ttl converter. Then the monitoring script on the RPI3 will verify its content and perform the appropriate action defined in Table III. The baud rate for serial communication will be set to 4800 bits per second (*bits/sec*).

TABLE III. Table of All Uplink Command

Command	HEX Uplink Command	HEX Uplink Argument
Begin Acquisitions	0x01	N/A
Stop Acquisitions	0x02	N/A
Set Shutter Time	0x03	Shutter Time in seconds (1-255)
Change Acquisition Mode	0x04	HEX Mode Identifier
Device Reset	0x05	N/A

TABLE IV. Table of Acquisition Modes

Acquisition Mode	Hex Mode Identifier	Description
Automatic Shutter Time	0x01	Shutter time determined automatically based on particle flux
Fixed Shutter Time	0x02	Shutter time fixed to set shutter time
Counting Mode	0x03	Configure MiniPIX to measure counts on the detector only
ToT Mode	0x04	Configure MiniPIX to measure time over threshold values
ToA Mode	0x05	Configure MiniPIX to measure time of arrival

### 4.2. Interfacing with HASP: EDAC and DB9 Connections

Our wiring will not change much from the last mission [1]. From the EDAC pins, we will join two of the 30 V leads together in parallel to supply power to the central power supply. Likewise, two of the ground leads will be used to ground the supply. A pair of 30 V and ground leads will also be used as input to the relay circuit in order to supply power to the pumps which require at least 24 V to operate. The last pair of 30 V and ground leads will be used as input to the punch and hold circuit mentioned in the previous section to power the solenoids which require at least 20 V to operate. Two temperature sensors will be connected by both analog leads from the EDAC connection. The corresponding ground pins will be used to ground them. These two sensors will be placed on each of the pumps.

We will use discrete commands in this mission. Two of the commands will be used to turn the astrobiology system on and off. This is only in case of emergency if we notice that the system is not responding to our serial commands. The other two discrete channels will be used to turn on and off the power of RESU in case that we notice an issue.

### 4.3. Interfacing with HASP: Serial Downlink

For the duration of the flight the serial downlink will be used to downlink the temperature and other various radiation statistics that will be computed directly on the RP3 as data is collected. It will also be used to downlink messages regarding the status of the payload, the command uplink status and error

# HASP Payload Application 2018

TABLE V. Table of all discrete commands to be used during flight

Command	Purpose	EDAC Pin	Description
Discrete 1	Astro. System ON	f	Initiates the pumps and collection systems
Discrete 2	Astro. System OFF	n	Shuts down the pumps and causes collection systems to retract
Discrete 3	RESU On	h	Powers up RESU
Discrete 4	RESU OFF	p	Shuts down RESU

messages. The data packets will be human readable so they can be analyzed directly as they are received from HASP. The packets will be delineated by new lines and we will use a simple one character header to differentiate between data packets and message packets. The format of the packets is still potentially subject to change but the preliminary design is outlined below.

TABLE VI. Data Packet Format

Data	Size (bytes)
d	2
MiniPIX Temperature	6
Dose Rate	6
Average Counts	5
Newline	1
Total Packet Size	20 bytes

TABLE VII. Message Packet Format

Data	Size (bytes)
m	2
Message Size	6
Message	String of length Message Size
Newline	1
Total Packet Size	Variable

## 5. THERMAL CONTROL PLAN

Based on our previous mission [1], we opted to have a similar thermal control plan but with a few changes. To simplify the payload construction and control, we opted for an semi-autonomous temperature monitoring and control system.

The Arduino will monitor the pumps and other devices for overheating. If the Arduino detects that a component, such as the pumps, then it will shut down the whole astrobiology system for a certain amount of time.

In the case of our payload experiencing colder temperatures, all of our devices will be able to operate beyond expected temperatures on the flight. Based on our previous mission [1], we found that heaters were unnecessary and that insulation proved to be more than adequate.

The temperature will be checked and recorded periodically for all devices, but it will not be downlinked.

In order to manage the temperature of the MiniPIX, it will be fitted with the same heatsink configuration as our 2017 flight. The internal temperature of the device will be recorded and downlinked to the flight control team at regular intervals. If the device is beginning to experience temperatures beyond what we would consider safe (above 70 °C) we can either reset the RP3 controlling the MiniPIX or fully shutdown the entire radiation subsystem.

# HASP Payload Application 2018

## 6. POWER AND WEIGHT BUDGET

In order to stay within the power constraints, a robust power supply will need to handle all the components of the payload. The power supply we will be using is the same PPM-DC-ATX-P by WinSystems INC that we used on our first flight [1]. During our last flight it operated flawlessly and powered our payload throughout the whole mission. It offers the desired number of +5 V and +12 V outputs needed to power the payload's electronics. This power supply effectively takes +30 V and steps it down to two +12 V and two +5 V outputs. One of the +12 V outputs goes to the Arduino since it can step down to the appropriate voltages internally while the other goes to a PWM motor for the solenoid. One of the +5 V outputs powers two analog sensors that will be sent to HASP through the EDAC connection (more on that in the next sections). The remaining +5 V output is converted to a USB power cable for the RP3. The power supply also has four ground outputs that will be used by each respective component.

TABLE VIII. Power and weight budget for SORA 2.0

Component	Voltage (VDC)	Current (mA)	Duty Cycle (%)	Power (mW)	Weight (g)
30 to 12 V DC/DC Converter	30	1500	100	45000	10
RESU and MiniPIX II	12	290	100	3480	15
Pump 1 Heater with driver	12	180	40	2160	2
Pump 2 Heater with driver	12	180	40	2160	2
Pump 1 w/ Solenoid	24	670	80	16080	1800
Pump 2 w/ Solenoid	24	670	80	16080	1800
Clean Box	N/A	N/A	N/A	N/A	10000
Structure w/ bolts	N/A	N/A	N/A	N/A	5000
Total	30	2.1 (peak)	100	45000	18764

## 7. PROCEDURES

### 7.1. Decontamination

#### 7.1.1. Objectives

Sanitization procedures are critical. They need to be checked and verified to ensure that our samples will not become contaminated. If the samples were to become contaminated it would make any possible bacterial collection data inconsequential.

#### 7.1.2. Sterilization Preflight

The payload will be built within the confines of a class 100 clean hood that is located inside of a class 10,000 clean room. Any tools that are used to construct the sampling box will be heat sterilized at 120 °C for 20 min. This will be followed by exposing each side of the container to germicidal UV-C (254 nm) light for 20 min and then soaked overnight in 91% isopropyl alcohol to denature proteins in any possible sources of contaminating bacteria. This sterilization method destroys close to 100% of all organisms and their endospores. To sterilize parts that would otherwise be damaged by the autoclave method they will be cleaned by hand with 91% isopropyl alcohol to kill microorganisms by denaturing proteins and dissolving the lipid membrane. Following this, the materials will be rinsed with a 95% ethanol (v/v) solution as an extra precautionary step to ensure complete decontamination. After all parts have dried, the sampling container will be constructed and placed in a gas-porous sterilization pouch and exposed to ethylene oxide (EO) at a concentration of 0.45-0.65 mg/m<sup>3</sup> to 0.65 mg/m<sup>3</sup> at 55 °C and 30-50 % RH for 4 hours to annihilate any

# HASP Payload Application 2018

spores and to provide another form of anti-bacterial treatment. The SMITH payload for HASP 2011 was processed in a similar fashion. Once the final HASP integration is ready for sampling and control containers are produced, the chambers will be sterilized and sealed. After the containers are integrated into the rest of the payload, the entire device will be placed in an autoclave bag for transportation.

## *7.1.3. Sterilization Post flight*

Before payload descent, we will shut off all of our systems. By powering down all the systems, the solenoids will seal the sampling container. Each team member involved in the recovery process will wear new latex gloves; cleaned with 91 % isopropyl alcohol. The payload will remain sealed until decontamination procedures are complete and the sampling containers are ready for processing. The payload will be disassembled under class 100 conditions and all tools used during this procedure will be either heat or 91 % isopropyl alcohol sterilized. Once in the clean room, the same procedures that were performed preflight will be performed post flight. The sampling box will then be packaged in a heat sterilized plastic outer container and transported back to the University of Houston for analysis.

## **7.2. Testing**

### *7.2.1. Vacuum Chamber*

There will be an initial testing phase that will include each component that will draw or supply power/current. During this phase, each component will receive power and transmit data to ensure proper functionality. Communication will be tested by sending commands to the system and receiving status updates in return. In addition to testing proper functioning of the pumps and solenoid valves, the clean box will be tested to ensure sanitation procedures are successful and verify that the materials inside the bottles within the clean box remain unfrozen. This initial phase is to be followed by an integration of components into their respective subsystems. Each subsystem will be tested to ensure functionality within itself and confirm actual power consumption and current drawn at various voltages. The subsystems will be thermally vacuum tested to determine thermal stability and general functionality at each phase of the flight (ascension, float, descent) for a total of 24 hours. Finally, a complete integration will complete the payload. The complete integration will be tested in the same manner as the subsystems to establish a fully functioning payload. Once this final phase is complete, the payload will be sealed after it has undergone sanitation procedures.

## **7.3. Integration Procedures**

### *7.3.1. Houston Integration*

For Astrobiology, we will try to determine the airflow through the system under normal ground level conditions and float conditions with as much precision as possible. We will run two pumps while monitoring their power consumption. The pumps, along with the temperature, humidity and pressure sensors and tubing will undergo extensive thermal vacuum testing in the range of  $-3^{\circ}\text{C}$  to  $25^{\circ}\text{C}$ , with a pressure range of 0 mbar to 10 mbar. The vacuum chamber tests will run for approximately 8 h to 15 h, to replicate conditions from the previous flights. In the past [1], the pumps were subjected to a temperature range of  $-30^{\circ}\text{C}$  to  $50^{\circ}\text{C}$  during integration and ran again for 8 h afterwards and prior to flight. The pumps have proven to function in extreme environments without an issues.

There will be several clean boxes used during the testing procedures to ensure stability of the materials and agarose solution under flight conditions. The multiple boxes will also allow for contamination and leak testing. Once the aforementioned astrobiology subsystem has been assembled, the sealed and sanitized clean



# HASP Payload Application 2018

box will be connected via the tubing from the pumps. This new assembly will be vacuum chamber tested under the same pressure and temperature conditions that are to be expected throughout the flight.

RESU will once again undergo rigorous testing in order to ensure proper operation. Once all components are collecting data we will run a test in the vacuum chamber under float conditions. If any of the sensors fail, we will gradually add components and vacuum test the system at each stage until we identify the source of the problem.

When the astrobiology assembly and the environmental subsystem have undergone separate and complete flight simulations in the vacuum chamber, the two will be combined to form a more complete assembly. This new assembly will then be vacuum chamber tested.

In near vacuum environments, electrical devices under continuous operation tend to build up heat as there is practically no thermal convection. Based off of the results from the last mission, we have decided the aluminum heat sink is the best option [1]. Once the MiniPIX has been tested separately it will be added to the assembly to make a final assembly that will be vacuum tested. The MiniPIX will be integrated with the RP3 via USB. Using the Pixet software, we will test known sources to measure the energy levels and particle flux to ensure that the MiniPIX has been properly calibrated.

## 7.3.2. HASP Integration

The integration team, which consists of all team members to date, will arrive at the integration site approximately 1 to 2 days before the scheduled tested. The first step of the integration will be to attach the payload to the HASP plate. Following attachment, it will be verified that the payload receives power from the HASP EDAC connector and is successfully sending and receiving operation commands from the ground. Our results for bacteria collection rely heavily on a low contamination risk setting pre and post flight, therefore, we think it best that the sampling system remains powered down until float altitude has been reached. We can offer a proxy for the integration testing in the form of a separate actuator and pump to confirm that commands are being received from the ground. Once everything is determined to be in working order the entire system will be shut down in preparation for the actual flight.

## 7.3.3. Post Integration Operations

After integration, the astrobiology system will be prepared for flight. Any issues or improvements needed will be done in the months before flight. For the rest of the systems, we will do a final check and have the payload ready for shipment. The payload will be shipped in a crate to New Mexico accordingly.

## 7.4. Flight Operations

Our systems are all automated, therefore the only flight operations to consider are to turn on the pumps once float conditions are achieved. The payload will be monitored via analog and serial downlinking to determine the appropriate time to turn on all systems.

## 7.5. Post-Flight Operations

Once the flight is complete the team will be on site to collect the astrobiology subsystem assembly, the radiation subsystem assembly, and the second RP3 responsible for storing all environmental data. Everything else can be shipped back to our facilities at a later date.

# HASP Payload Application 2018

## 8. IN-FLIGHT FAILURE CONTINGENCY PLAN

If for some reason the sampling system fails, commands can be uplinked to the control system that allow for subsystem resets. If the temperature falls below component operating conditions, the heater associated to that particular subsystem will automatically turn on until operating conditions are restored and the system is operational. If downlinked data shows extreme overheating or any sort of abnormality that could result in damage to HASP or other payloads, we will shut down all systems through the discrete command provided by HASP.

## 9. PROJECT MANAGEMENT

### 9.1. Team Structure

*Faculty Mentor:*

**Andrew Renshaw**

Physics Department

[arensaw@central.uh.edu](mailto:arensaw@central.uh.edu)

*Project Leader:*

**Samuel Morelos**

Physics B.S. and teachHouston, Fall 2017

[sagarciamorelos@uh.edu](mailto:sagarciamorelos@uh.edu)

*Team Coordinators:*

**FreEtta Brooks**

Physics B.S., Fall 2017

[fbrooks@uh.edu](mailto:fbrooks@uh.edu)

**Steven Oliver**

Physics B.S., Spring 2018

[sjoliver2@uh.edu](mailto:sjoliver2@uh.edu)

**Andrew Walker**

Computer Science B.S., Spring 2018.

[awalker2@uh.edu](mailto:awalker2@uh.edu)

### 9.2. Roles and Responsibilities

- PI Dr. Andrew Renshaw
  - Attend weekly team meetings and provide general research team guidance
  - Review project design and final products for submission to HASP
  - Attend monthly teleconferences.
  - Equipment procurement

# HASP Payload Application 2018

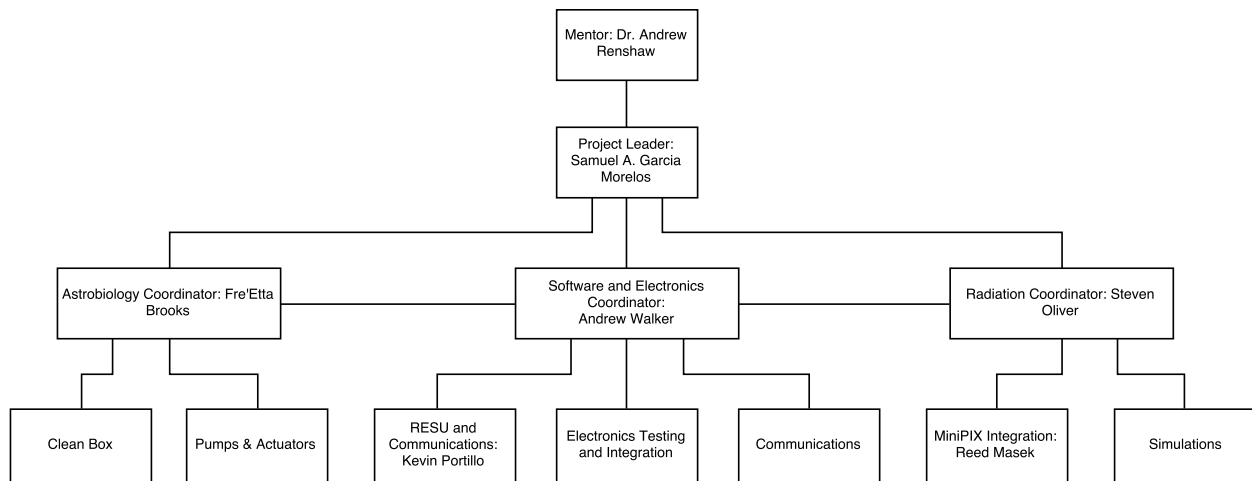

FIG. 8. Team role tree for the current SORA 2.0 UH team.

- Project Leader - Samuel A. Garcia Morelos
  - Interface with HASP Flight Control Team and act as team main point of contact
  - Compile monthly reports and submit to HASP
  - Attend monthly teleconference with HASP
  - Coordinate with PI on administration tasks and internal group business
  - Coordinate meetings and assign tasks with deadlines
  - Approve designs, tests, ideas, and any work related to HASP and payload
  - Final decisions on staffing (Staffing decisions will be a group decision overall)
- Electronics and Communications Coordinator - Andrew Walker
  - Do necessary reserach for finalizing work
  - Coordinate information, tasks, and deadlines with subgroup
  - Approve work done by subsystem team
  - Write bimonthly updates along with detailed reports from subsystem meetings
  - Make detailed presentations, if necessary, for weekly team meetings
  - Report to project leader and PI with any project changes, issues encountered, and any external communications.
  - CC PI and Project Leader in all emails for external communications
  - Perform other such duties as the Project Leader or PI may specify
- Astrobiology Coordinator - Fre'Etta Brooks
  - Do necessary reserach for finalizing work
  - Coordinate information, tasks, and deadlines with subgroup
  - Approve work done by subsystem team
  - Write bimonthly updates along with detailed reports from subsystem meetings
  - Make detailed presentations, if necessary, for weekly team meetings
  - Report to project leader and PI with any project changes, issues encountered, and any external communications.
  - CC PI and Project Leader in all emails for external communications
  - Perform other such duties as the Project Leader or PI may specify

# HASP Payload Application 2018

- Radiation Coordinator - Steven Oliver
  - Do necessary reserach for finalizing work
  - Coordinate information, tasks, and deadlines with subgroup
  - Approve work done by subsystem team
  - Write bimonthly updates along with detailed reports from subsystem meetings
  - Make detailed presentations, if necessary, for weekly team meetings
  - Report to project leader and PI with any project changes, issues encountered, and any external communications.
  - CC PI and Project Leader in all emails for external communications
  - Perform other such duties as the Project Leader or PI may specify
- RESU Lead Programmer - Kevin Portillo
  - Do necessary reserach for finalizing work
  - Coordinate with team
  - Make detailed presentations, if necessary, for weekly team meetings
  - Report to project leader and PI with any project changes, issues encountered, and any external communications.
  - CC PI and Project Leader in all emails for external communications
  - Perform other such duties as the Project Leader or PI may specify
- MiniPIX Integration and Testing - Reed Masek
  - Do necessary reserach for finalizing work
  - Coordinate with team and subsystem coordinator
  - Make detailed presentations, if necessary, for weekly team meetings
  - Report to project leader and PI with any project changes, issues encountered, and any external communications.
  - CC PI and Project Leader in all emails for external communications
  - Perform other such duties as the Project Leader or PI may specify
- Team Member
  - Do necessary reserach for finalizing work
  - Coordinate with team and subsystem coordinator
  - Make detailed presentations, if necessary, for weekly team meetings
  - Report to project leader and PI with any project changes, issues encountered, and any external communications.
  - CC PI and Project Leader in all emails for external communications
  - Perform other such duties as the Project Leader or PI may specify

# HASP Payload Application 2018

## 9.3. Timeline

TABLE IX. Timeline for the 2018 SORA 2.0 Mission

Month of 2018	Description of Work
<b>January</b>	<ul style="list-style-type: none"> <li>* Secure funding</li> <li>* Create and finish budget for mission</li> <li>* Make inventory of hardware</li> <li>* Procure hardware/software</li> <li>* Start designs of SORA 2.0</li> <li>* Update RESU</li> <li>* Upgrade vacuum chamber</li> <li>* Recruit new members</li> </ul>
<b>February</b>	<ul style="list-style-type: none"> <li>* Continue with work from January. Funding must be secured by end of March.</li> <li>* Have finished list of inventory</li> <li>* Finalize upgrades to vacuum chamber</li> <li>* Continue recruitment and finalize by end of month.</li> <li>* Continue design work of SORA 2.0</li> <li>* Finish RESU upgrade</li> </ul>
<b>March</b>	<ul style="list-style-type: none"> <li>Obtain funding by the end of this month. Finish all tasks from the previous two months and transition into building phase.</li> <li>* Have all hardware/software orders in by the end of the month</li> <li>* Begin PSIP, have draft by end of the month</li> </ul>
<b>April</b>	<ul style="list-style-type: none"> <li>* Order remaining items if needed</li> <li>* Finish PSIP by April 25th</li> <li>* RESU and MiniPIX integration and testing</li> <li>* Upgrade clean room and prepare for astrobiology work</li> </ul>
<b>May</b>	<ul style="list-style-type: none"> <li>* PSIP and FLOP development</li> <li>* Finalize integration of RESU and hardware</li> <li>* Continue working on astrobiology upgrades</li> </ul>
<b>June</b>	<ul style="list-style-type: none"> <li>Final PSIP due June 27th</li> <li>*Finalize astrobiology upgrades and ready for integration</li> <li>* Testing in lab</li> </ul>
<b>July</b>	<ul style="list-style-type: none"> <li>Final FLOP due July 31st</li> <li>* Make changes from testing and continue tests</li> </ul>
<b>August</b>	<ul style="list-style-type: none"> <li>Payload Integration (August 4 - 8)</li> <li>*Have all payload work done and ready for flight</li> </ul>
<b>September</b>	* Launch and recovery TBA
<b>October</b>	Debrief and analyze all data from flight
<b>November</b>	Have final report by end of November
<b>December</b>	Final Report due on the 8th

## 9.4. Funding

Funding sources will be local contributions - applying for funding through the Physics Department, the College of Natural Science and Mathematics, The University of Houston Division of Research, and local organizations and companies willing to support this endeavor.

# HASP Payload Application 2018

---

- [1] S.A. Garcia Morelos, F.Brooks, S.Oliver, A.Walker, K.D. Portillo, R.B. Masek, D.Mroczek, D.Pena, J.Juarez, A.Cruz, D. Henandez, S.George, D. Pattison, A.L.Renshaw. *Scientific Report for the UH Team*. SORA 2017 Mission Webpage. <http://laspace.lsu.edu/hasp/groups/Payload.php?py=2017&pn=10>.
- [2] MiniPIX - Miniaturized Portable USB Photon Counting Camera. (n.d.). Retrieved February 02, 2017, from <http://advacam.com/camera/minipix>.
- [3] Christner, B., Alleman, M., Bryan, N., Burke, S., Guzik, T.G., Granger, D., King, G. (2013) *LSU HASP2013 PDF*. Baton Rouge: Louisiana Space Consortium.
- [4] Extremophiles <http://www.nytimes.com/2013/02/07/science/living-bacteria-found-deep-under-antarctic-ice-scientists-say.html>.
- [5] Canales D. C. and Ehteshami A., *An attempt to sample atmospheric bacteria*, Houston, TX, 2015, January 11.
- [6] Urbar, J., Scheirich, J., Jakubek, J., 2011. Medipix/Timepix cosmic ray tracking on BEXUS stratospheric balloonflights. Nucl. Instrum. Methods A 633, S206-209.
- [7] Valve data sheet <http://www.generant.com/Literature/Series%20VRV%20Product%20Literature.pdf>.
- [8] ADVACAM at [advacam.com](http://advacam.com).
- [9] Medipix collaboration at <https://medipix.web.cern.ch/>.
- [10] 22 George, S., *Dosimetric Applications of Hybrid Pixel Detectors*, University of Wollongong, Australia, 2015.
- [11] Alfonso Garcia Morelos, S. (2016, October 13). *A Novel Microbe Trap*. Presentation at UH Undergraduate Research Day. <http://www.uh.edu/honors/undergraduate-research/>