



HASP Student Payload Application for 2018

Payload Title: CATCHING RAYS – A Mission to Measure Primary Cosmic Rays in the Upper Stratosphere using the HASP			
Institution: SDSMT / Sanford Underground Research Facility (SURF)			
Payload Class (Enter SMALL, or LARGE): SMALL		Submit Date: 12/15/17	
<p>Project Abstract: The primary objective of this project is to design a cosmic ray detector capable of measuring primary cosmic ray particles first in a standard weather balloon, then in HASP, and ultimately, in a CubeSat mission. The ionizing particles that are caught in the Earth's magnetic field and bombard the upper atmosphere effect everything from weather to electronics on board aircraft. Understanding the particles and their reactions with the atmosphere are important. When solar activity is at a minimum, as it is currently, a greater portion of the primary particles come from outside the solar system. These galactic cosmic rays can be as heavy as iron and range to higher energies than particles in the solar wind. They are quite interesting scientifically.</p> <p>The payload under development by the Sun Catchers team is modeled after the Cosmic Ray Telescope for the Effects of Radiation (CRaTER) experiment on the Lunar Reconnaissance Orbiter (LRO) mission [1]. The South Dakota Catching Rays payload will consist of two silicon diode detectors, one thin and one thick, configured as a telescope. In addition to the silicon telescope, the payload will also contain a Geiger counter for detecting secondary gamma rays, and sensor data that records atmospheric conditions.</p>			
Team Name: South Dakota Sun Catchers		Team or Project Website:	
Student Leader Contact Information:		Faculty Advisor Contact Information:	
Name:	Jacob Fonkert	Jason Ash	Peggy Norris
Department:	Mechanical Engineering	Mechanical Eng	SURF
Mailing Address:	SDSMT – ME 501 East Saint Joseph St.	SDSMT – ME 501 East Saint Joseph St.	630 E. Summit St
City, State, Zip code:	Rapid City, SD 57701	Rapid City, SD 57701	Lead, SD 57754
e-mail:	Jacob.Fonkert@mines.sdsmt.edu	Jason.ash@sdsmt.edu	pnorris@sanfordlab.org
Office Telephone:		605-355-3736	605-722-5049
Mobile Telephone:	605-850-9395		605-645-6325

Catching Rays

A Mission to measure Primary Cosmic Rays in the Upper Stratosphere using the HASP

South Dakota Sun Catchers: A collaboration of students and faculty from South Dakota School of Mines and Technology, the Sanford Underground Research Facility, Spearfish High School, Sturgis Brown High School, and Custer High School

Introduction

The South Dakota Solar Eclipse team was new to ballooning when it joined the national solar eclipse ballooning project in the summer of 2016, with funding from the South Dakota Space Grant Consortium and basic equipment from the national project. The team was a collaboration of undergraduates (primarily a senior design team in mechanical/electrical engineering at South Dakota School of Mines and Technology (SDSMT), faculty, high school teachers and students and community members. The main payload effort for the solar eclipse focused on livestreaming during the eclipse. The initial plans for the secondary payload was to measure primary and secondary cosmic rays and look for changes with atmospheric changes during the eclipse. In the end, the livestreaming payload was enough of a challenge for this novice team that only secondary cosmic ray muons were measured during the eclipse, and the primary cosmic ray detector was postponed until this fall.

For the 2017-2018 school year, the team has renamed itself the South Dakota Sun Catchers and it is working on the primary cosmic ray detector. The team consists of a new senior design team in mechanical engineering augmented by members of the newly formed SDSMT CubeSat team, plus high school students and teachers. The inclusion of high school students, teachers and underclassmen strengthens the collaboration, encourages peer mentoring, and enables continuity across projects and school years.

Payload Description

The objectives of the senior design team is to design a cosmic ray detector capable of measuring and classifying primary cosmic ray particles first in a standard weather balloon, then in HASP. The payload under development by the Sun Catchers team is modeled after the Cosmic Ray Telescope for the Effects of Radiation (CRaTER) experiment on the Lunar Reconnaissance Orbiter (LRO) mission [1]. The South Dakota Catching Rays payload will consist of two silicon diode detectors, one thin and one thick, configured as a telescope. The CRaTER experiment uses three such telescopes. Due to cost constraints, the Catching Rays telescope will be smaller in diameter than the detectors flying in the LRO.

The design of the cosmic ray telescope will maximize efficiency and particle identification across a range of particle energies and types. Once a particle collides with the cosmic ray detectors the data must be stored and filtered in order to be meaningful. This data must then be paired to pressure and temperature readings in order to establish the environmental conditions when the particle was detected. A sensor payload will provide pressure and temperature data.

The cosmic ray detector is required to withstand the elements that it would experience as it traveled to the upper atmosphere. For the initial balloon flights, it is being designed to be within the FAA regulations and more importantly within non-reporting regulations.

The FAA regulations for an unmanned free balloon are as follows:

- _ The smallest surface area on a payload must have a size to weight ratio no larger than 3oz/in²
- _ No single payload can weigh more than 6 lbs

_ The total weight of the payloads must not weigh more than 12 lbs

These regulations must be followed to legally fly balloons in the United States and allow for flying balloons without notifying the FAA.

The other requirements are based on the environment and physical capabilities of the equipment. The total weight of the payload was required to be under 9 lbs. This is due to the lift capabilities of size of weather balloon that was available. While it is possible to have higher payload weight, the balloon must be filled with more helium. This lowers the max altitude that the balloon can reach, which is not optimal. The equipment was required to withstand temperature ranges of -40 to 80_F. The pressure sensors had to be able to detect pressure in a range from 0.162 to 13.2psia. These temperature and pressure requirements are based on the environment at different points in the atmosphere.

These requirements make the design ideal for a SMALL payload station within the HASP launch.

Detector Subsystem

The most important aspect of the detector is the ability to accurately measure primary cosmic rays. The majority of these are protons with a small number of particles as heavy as iron nuclei. Silicon diode detectors have excellent energy resolution, and a $\Delta E-E$ telescope, while more expensive than other options, utilizes a well proven technique for particle identification. Figure 1 – from the CRaTER technical design paper [1], show simulations using the code GEANT [2] of cosmic ray signals in a silicon diode telescope. The detector will generate the most complete data for protons in the 4-13 MeV range and for heavier particles with energies greater than a few MeV.

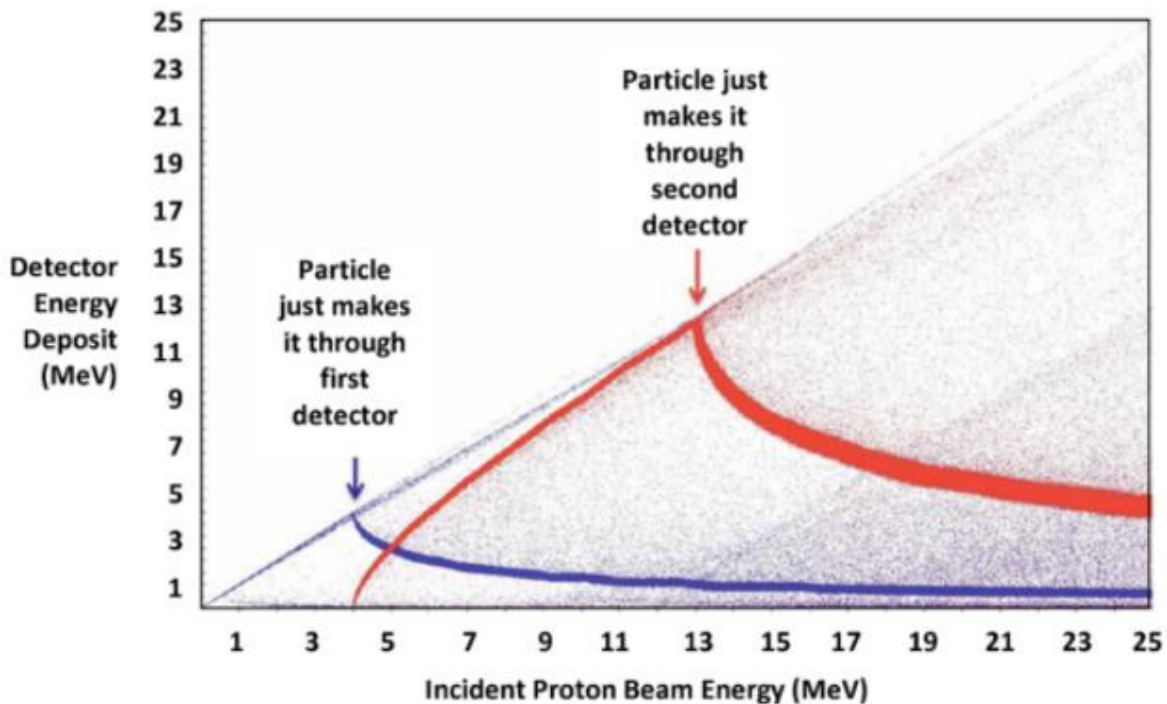

Figure 1: Simulation Plot of Cosmic Ray Signals in a Silicon Diode Telescope (from Reference 1)

A commercial Geiger-tube based secondary radiation detector will be included with the payload. The data will be used to correlate particle type and energy of the primary cosmic rays with the

formation of secondary particles in the atmosphere. This will be a very similar design to the Vernier radiation monitor [3] which was used for the solar eclipse balloon flight.

Sensor subsystem

For the payload sensors, there are several different measurements that need to be considered. The main data needed to supplement the cosmic ray data is the payload ascent rate, descent rate, orientation during flight, inside and outside temperatures, inside and outside pressures, and altitude.

For the inertial measurements, an inertial measurement unit (IMU) can monitor the ascent rate, descent rate, payload orientation during flight, and the landing speed of the payload. This information is useful to understand the flight dynamics of the payload system.

For the temperature measurements, temperature sensors were considered to monitor the temperature inside and outside the payloads. Monitoring the operating temperature inside the payload is important for the project because the balloon system travels through cold parts of the atmosphere that can have an effect on the components inside the payloads. If the operating temperature inside the payloads drops near or below the operating temperature of the payload components, it would be necessary to include a heater in the payload system.

Another reason the temperature measurements are necessary is because the gain read by the cosmic ray detector is affected by the temperature of the detector. This was measured for the detectors used in CRaTER [1], and on average, the gain variation of the thick silicon diodes is approximately 0.1% and the gain variation of the thin diodes is approximately 0.5% [1]. Although, this temperature dependence is small, the temperature inside the payload should be monitored to make sure the correct gain adjustments.

A measurement of the temperature and air pressure outside the payload will provide data to help interpret the interactions between the primary cosmic rays and particles in the atmosphere. These interactions lead to showers of secondary particles, some of which reach the surface of the earth. The depth of penetration of the primary particles in the atmosphere is dependent on the energy and particle type, but also on the air pressure and temperature.

Figure 2 shows a block diagram of the detector payload electronics as it would be configured for HASP.

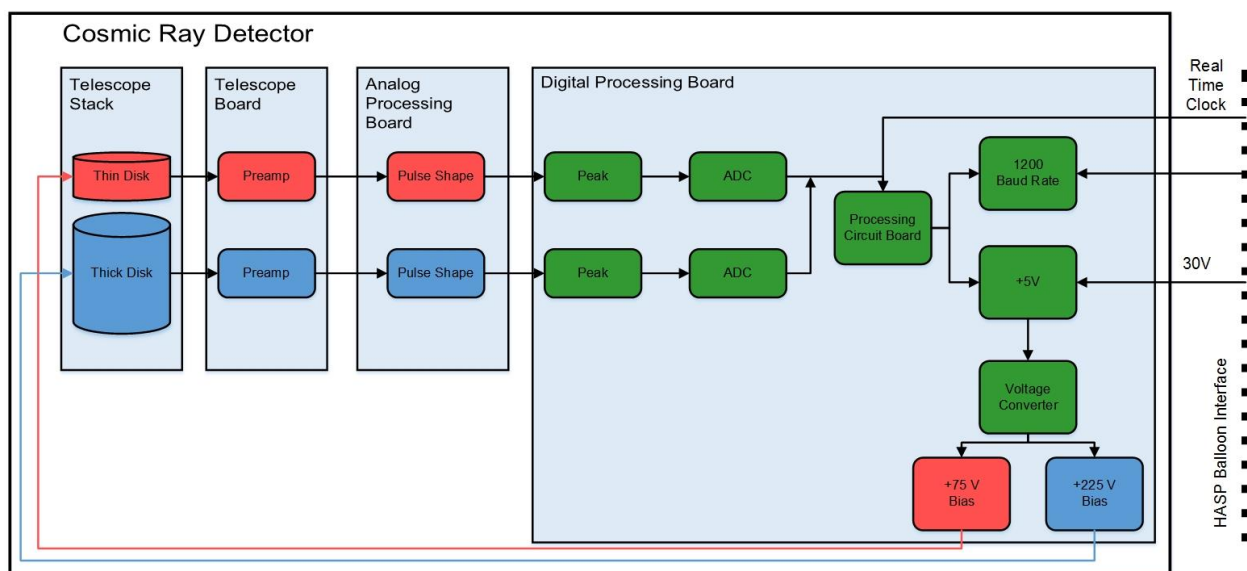

Figure 2: Functional Block Diagram of Cosmic Ray Detector

Power subsystem

For our system to accurately gather data, a medium voltage, low current bias voltage is required for the two silicon diode detectors (75V & 225V, respectively). Our payload power distribution system (PPDS) will be responsible for providing this voltage, as well as providing power for the Data Acquisition (DAQ) Board.

The current plan is to adapt a board developed by Fermi National Accelerator Laboratory (Fermilab) Data Acquisition board [4] for another type of cosmic ray detector. This DAQ board requires 5V, with a maximum current draw of 1A. This information is per the board manufacturer, and has been independently verified by our testing. The PPDS will be responsible for stepping down the 30V HASP supply voltage to power this board. To keep things simple, we plan to utilize a commercial off-the-shelf (COTS) buck converter for this purpose. Assuming a conversion efficiency of 85%, this gives ~6W of required input power.

The bias voltage required for the detector subsystem will also be provided by COTS components, as minimal current draw is expected. Presently, our estimates of power consumption for the bias circuitry is 0.55W.

A summary of these power figures is shown in Table 1. Given that the HASP platform can provide 30V @ 0.5A (15W) for our payload class, we are well within margin. In addition, we plan on implementing fuse protection for each subsystem, to ensure that any malfunctions are kept localized to the subsystem and won't cause total mission failure by blowing the main payload fuse (provided by HASP).

Table 1. Overall Power Requirements

	Arduino	Detector Power	Bias Power	Total	HASP Power
Expected	1W	6W	0.55W	7.55W	15W
Derated	1.25W	7.5W	.69W	9.44W	12W

Telemetry subsystem

Because the HASP flight is substantially longer than a standard weather balloon flight, data from the cosmic ray detector and sensors will be downloaded periodically in case of component failure. Copies of this data will be stored on the systems SD card as well. The on-board controller will periodically receive GPS information from the HASP flight system which it will use to update its local clock to timestamp data packages, as well as track and store its position. Since data collection run times will be on the order of minutes for the DAQ board, the controller can send multiple copies of the data collected during each run to the HASP flight controller (using the format shown in Table 2) while the DAQ board is collecting data.

The functionality of Serial commands sent to the payload controller from the HASP Flight system include, but are not limited to:

- Modification of the Data Run duration
- Requests for re-sending corrupted data
- Error Management (register overflows, hardware communication failure, etc)

Table 2. Telemetry Package Structure

Byte	Bits	Description
1	0-7	Device ID
2-5	0-31	Message Timestamp (Seconds since 1/1/1970)
6	0-7	Record Size (Bytes)
7	0-7	Least significant 8 bits of the record checksum
8-11	0-31	Timestamp of beginning of data run (Seconds since 1/1/1970)
12	0-7	Signed Temperature value before data run(C)
13	0-7	Barometric pressure before data run(0.1 psia)
14-15	0-15	MSL Altitude before data run (0.1 m)
16-24	0-63	Ch1 Singles Count
25-33	0-63	Ch2 Singles Count
34-42	0-63	Coincidence count
43-46	0-23	Elapsed Data Run time (ms)
47	0-7	Signed Temperature value after data run (C)
48	0-7	Barometric pressure after data run (0.1 psia)
49-50	0-15	MSL Altitude after data run (0.1 m)
51	0-7	System Status

Management Structure and Organization

South Dakota School of Mines and Technology has a strong base of STEM students with interest in space applications. The student club, Students for the Exploration of Space (SEDS) is quite active and there are several student teams competing each year at various NASA-related design competitions (e.g. Moonrockers). This year, two undergraduate students who interned at NASA facility in the summer of 2017 came back with an interest in CubeSats, and have started a CubeSat club, with the goal of designing a payload within a few years. The HASP launch project has been adopted by the CubeSat club as a first project, leading up to a future proposal for a CubeSat launch.

Much of the design of the Catching Rays payload has been done by six members of a senior design team in Mechanical Engineering (ME). They are working closely with students from the CubeSat club to bring some electrical and computer engineering expertise into this project. The team is mentored by a faculty member in ME (Prof Jason Ash) and Dr. Peggy Norris, Deputy

Director of Education and Outreach for the Sanford Underground Research Facility. Dr. Norris is a physicist with an interest in cosmic rays and radiation effects and is the ‘customer’ for the senior design team.

Currently the SDSMT senior design team has been acting as the project team for this project, with some input from other SDSMT students who were part of the eclipse project. Shortly after the beginning of the spring semester, the team will be meeting with the CubeSat club to do succession planning: identifying students who will be on campus during the summer and available to take over lead roles on this project.

Table 3. Student Leads for HASP Payload Project

Lead Role	Description	Name
Project Manager	Will work with all subgroups, interface with faculty mentors and HASP management, be responsible for timeline and all milestones and reports.	Jacob Fonkert, Senior ME Major, Jacob.fonkert@mines.sdsmt.edu
Systems Integration	Will work on integrating all systems with HASP requirements; will attend testing and qualification	Sarah Kelly, Junior ChemEng Major, sarah.kelly@mines.sdsmt.edu
Detector Subsystems	Will adapt primary and secondary cosmic ray payloads (detector and electronics) for HASP platform	Aaron Vogel, Senior ME Major, aaron.vogel@mines.sdsmt.edu
Sensor Subsystems	Will adapt current and future sensor payloads to HASP platform	Brandon Lind, Senior ME Major, brandon.lind@mines.sdsmt.edu
Power subsystems	Will be responsible for all power needs and integrating with HASP power sources/requirements	Dakotah Rusley, Junior EE/CE Major, and NASA Pathways Fellow Dakotah.rusley@mines.sdsmt.edu
DAQ/Telemetry systems	Will be responsible for all data acquisition and integrating with HASP telemetry requirements	Zachary Christy, Junior EE/CE Major, Zachary.christy@mines.sdsmt.edu

The team hopes, funding permitting, to send 2-3 students each to the integration activities in the summer and the launch in the fall.

Table 4 shows a timeline for completion of this project.

Table 4. Preliminary Timeline and Milestones

Date (all 2018)	Milestone
Jan	1. Order all additional hardware (long lead items ordered already). 2. Team recruitment and training.
Feb	3. Design and build detector mount. 4. Modify DAQ board.
Mar- Apr	5. Preliminary system testing with backup detectors. 6. Power and interface systems development 7. Telemetry system development 8. Balloon Flight 1 – Test sensor board and secondary detector system
Apr 28	9. Preliminary PSIP Document due 10. Balloon Test Flight 2 – test primary detector telescope
May	11. Develop flight operations plan 12. Continued testing and calibration of detectors
June	13. (tentative) Calibrate telescope in proton beam at LBNL (funding permitting)
June 29	14. Final PSIP Document due
July 23- 27	15. Systems testing at CSBF in Palestine, TX
July 26	16. Final FLOP Document due
Sept 1-7	17. Flight preparations and launch
Dec 7	18. Final flight and science report

The detector and sensors are being purchased with the remaining funds from a South Dakota Space Grant Consortium (SDSGC) funded Project Innovation grant which provided funding for the eclipse ballooning project. The grant expires in April 2018. A small amount of funding for the team is part of the SDSGC 2018 base budget; we will be applying for a 2018-2019 Project Innovation Grant for travel and other expenses for the HASP launch should this proposal be accepted.

Payload Specifications

Cosmic Ray Subsystem

The silicon surface barrier charged particle detectors are available from Ortec™; specifications, are given in Table 5 for the Type B detectors ordered.

For this application, two detectors have been ordered. Each has an active area of 150 mm² and the thin detector is 150μ thick and the thick one 1000μ thick. The detectors have been ordered in a transmission mount (T-Mount) with a microdot cable; dimensions are given in Figure 3.

Table 5. Detector specifications [6]

Chief Application	Particle identification, telescopes of detectors (Nuclear Physics and Chemistry-Space Physics)
Detector Type	Totally Depleted Silicon Surface Barrier
Starting Material	Si
Range of Active Area (mm²)	50-450
Range of Active Thickness (μm)	150-2000
Warranted Operating Temperature Range*	+25°C to -30°C
Diode Structure	Gold — N-type Si Aluminum Total Depletion
Nominal Equivalent** Stopping Power of Windows	Entrance - 800 Å Si Exit - 2250 Å Si

Dimensions for 150 mm² detector

W = 13.8 mm

X = 26.1 mm

Y = 7.9 mm

Z = 9.9 mm

Tolerance ± 0.3 for X, Y, Z and ± 0.5 for W

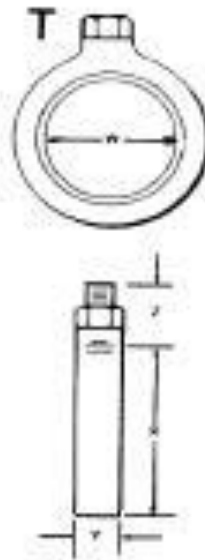

Figure 3. Detector Dimensions [5]

Sensor Subsystem

The design team considered cost, reliability, implementation, and accuracy and decided to use the BNO055 Absolute Orientation sensor for the inertial measurements and the Altimeter module MS5607 to measure the temperature, pressure, and altitude inside and outside the payloads.

According to the Adafruit website for the BNO055, this sensor can record the following data [6]:

- Absolute Orientation (Euler Vector, 100Hz). Three axis orientation data based on a 360 sphere
- Absolute Orientation (Quaternion, 100Hz). Four point quaternion output for more accurate data manipulation
- Angular Velocity Vector (100Hz). Three axis of 'rotation speed' in rad/s
- Acceleration Vector (100Hz). Three axis of acceleration (gravity + linear motion) in m/s²
- Magnetic Field Strength Vector (20Hz). Three axis of magnetic field sensing in micro Tesla (uT)
- Linear Acceleration Vector (100Hz). Three axis of linear acceleration data (acceleration minus gravity) in m/s²
- Gravity Vector (100Hz). Three axis of gravitational acceleration (minus any movement) in m/s²

According to the Altimeter module technical document, the sensor can record the following data [7]:

- Pressure from a range of 0.1 psia to 17.4 psia
- Temperature from a range of -40°C to 85°C , with a resolution of $< 0.1^{\circ}\text{C}$
- Altitude with a resolution of 20 cm

These sensors will be interfaced using an Arduino microcontroller. The data collected from these sensors will be stored onto an SD card module to be analyzed after the balloon payloads land.

Preliminary Drawings

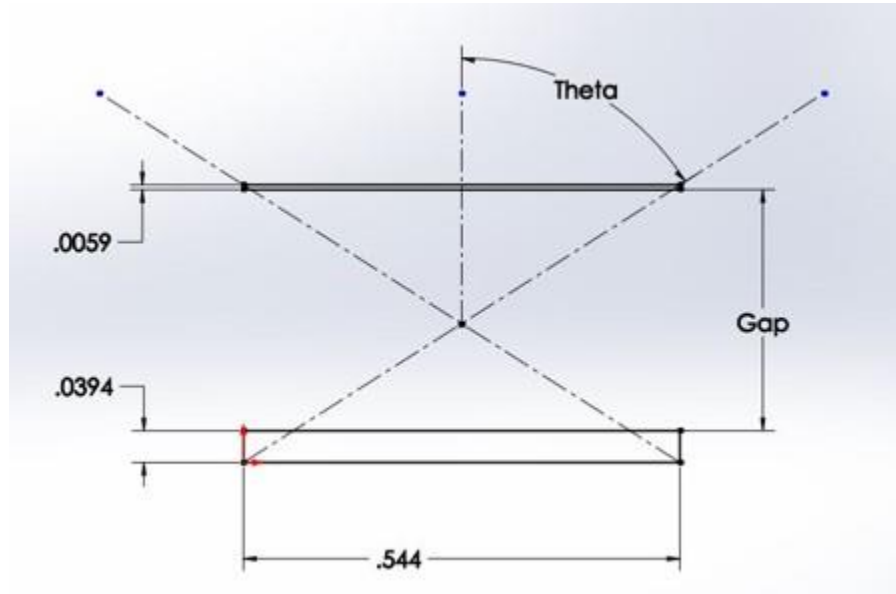

Figure 4: Viewing Angle of Detector

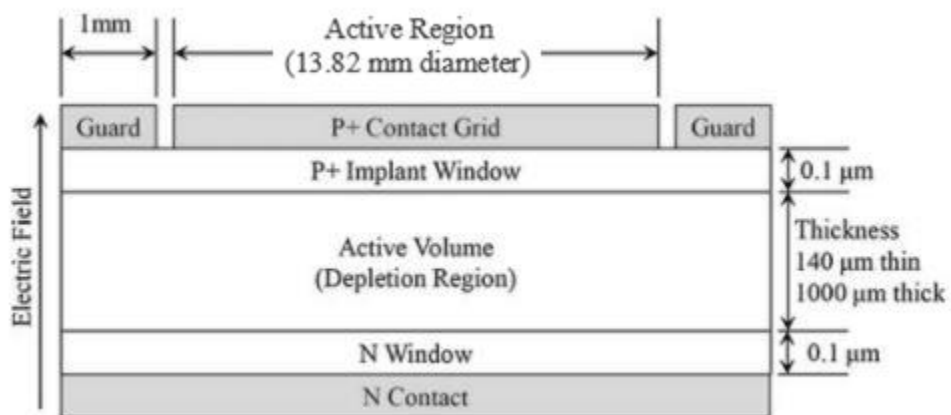

Figure 5. Schematic cross section of the silicon detector.

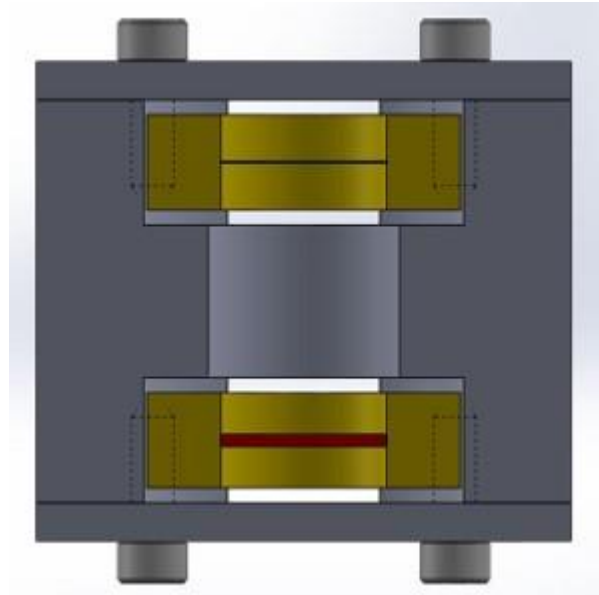

Figure 6: Detector Mounting

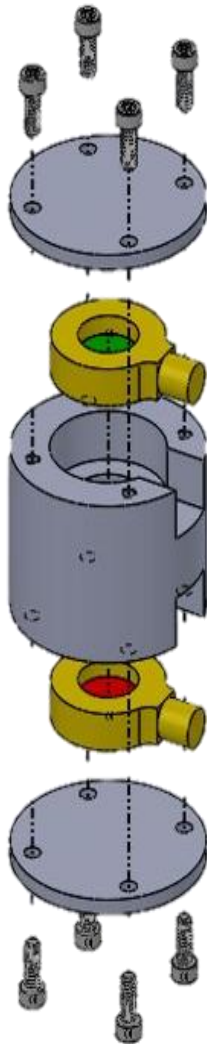

Figure 7: Expanded View of Mounting

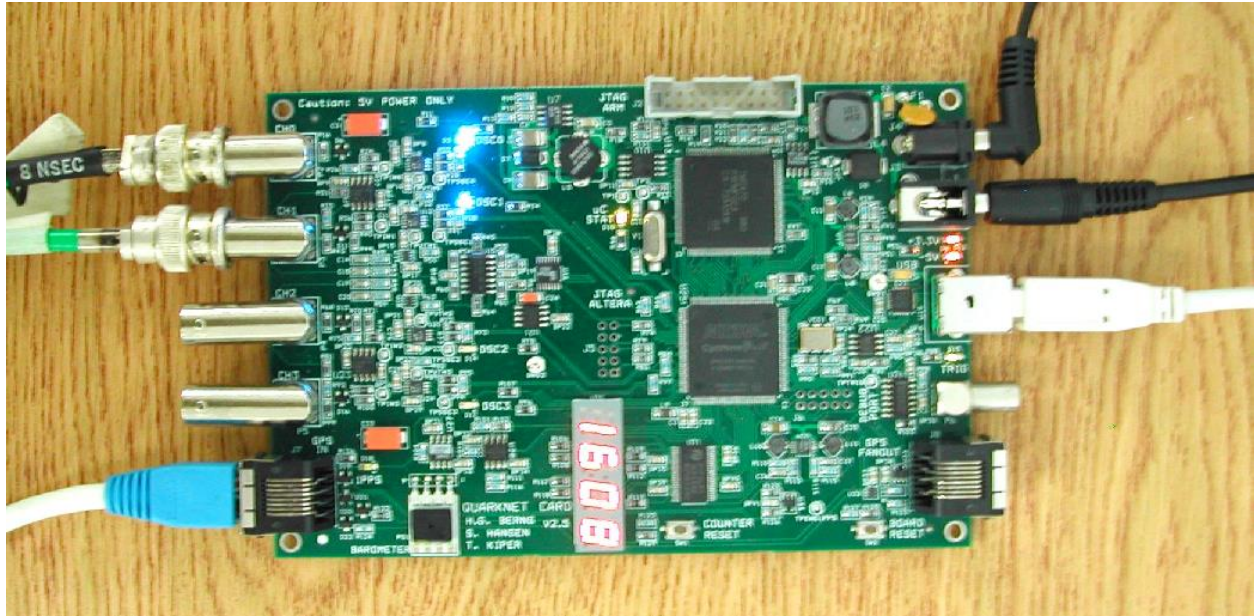

Figure 8: Fermilab Data Acquisition Board [4]

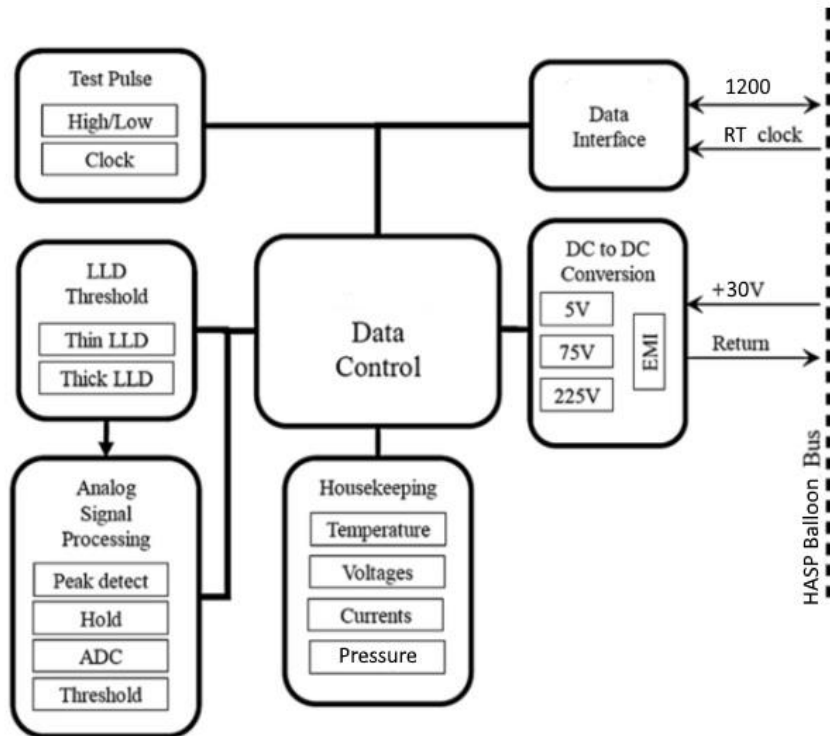

Figure 9. Functional Block Diagram of Flight System

References

- [1] H.E. Spence, A.W. Case, M.J. Golightly, T. Heine, B.A. Larsen, J.B. Blake, P. Caranza, W.R. Crain, J. George, M. Lalic, A. Lin, M.D. Looper, J.E. Mazur, D. Salvaggio, J.C. Kasper, T.J. Stubbs, M. Doucette, P. Ford, R. Foster, R. Goeke, D. Gordon, B. Klatt, J.O'Connor, M. Smith, T. Onsager, C. Zeitlin, L.W. Townsend and Y. Charara. *CRAaTER: The Cosmic Ray Telescope for the Effects of Radiation Experiment on the Lunar Reconnaissance Orbiter Mission*, Space Sci Rev 150, 243 (2010).
- [2] S. Agostinelli, et al. *Geant4 – a simulation toolkit*, Nuclear Instruments and Methods A 506, 250 (2003).
- [3] Vernier Corporation, <https://www.vernier.com/files/manuals/vrm-btd.pdf>.
- [4] J. Rylander, T. Jordan, J. Paschke, and H-G Burns, *Quarknet Cosmic Ray Muon Detector User Manual, Series '6000' DAQ*, 2010, https://quarknet.org/sites/default/files/cf_6000crmdusermanual-small.pdf
- [5] ORTEC™, *B-series brochure*, <http://www.ortec-online.com/-/media/ametektortec/brochures/b-series.pdf>
- [6] Datasheet for BNO055 Sensor, https://cdn-shop.adafruit.com/datasheets/BST_BNO055_DS000_12.pdf
- [7] Datasheet for Altimeter MS5607, <http://www.te.com/commerce/DocumentDelivery/DDEController?Action=srchtrv&DocNm=M55607-02BA03&DocType=Data+Sheet&DocLang=English>