



HASP Student Payload Application for 2018

Payload Title: Flight test of CITIES supporting hardware on the High Altitude X-Ray/Gamma-Ray Detector Testbed (HAXDT)		
Institution: University of Minnesota, Twin Cities		
Payload Class (Enter SMALL, or LARGE): SMALL		Submit Date: December 15, 2017
Project Abstract: The High Altitude X-Ray/Gamma-Ray Detector Testbed (HAXDT) is a platform used for flight testing prototype sensors, sensing concepts and supporting hardware for CubeSats. HAXDT has a 3U CubeSat form factor and is designed to interface with the High Altitude Student Platform (HASP) adapter plate. It hosts the CsI(Tl) Incident Energy Spectrometer (CITIES); a major redesign from the legacy Gamma Ray Incidence Detector (GRID) flown on HASP in previous years. Developed at the University of Minnesota, CITIES is Gamma-ray and hard X-ray detector optimized for making accurate positioning, navigation, and timing (PNT) measurements, as well as for studying solar weather. On the HASP 2018 flight, HAXDT will be hosting most of the supporting hardware and software that will be implemented on two University-built 3U CubeSats: Experiment for X-ray Characterization and Timing (EXACT) and Signal of Opportunity Ranging and Timing Experiments (SOCRATES). These two missions will host their own versions of CITIES in order to fulfil their science and engineering goals. The HASP 2018 flight will serve as a stepping-stone to validate the current designs for the supporting hardware of both satellites. More specifically, the flight will be used to test the reprogramming abilities of the on-board processors through radio communication outside of a lab environment. Likewise, the secondary goal for the flight will be to validate the detector data processing capabilities of the Field Programmable Gate Array (FPGA) implemented after the HASP 2017 flight.		
Team Name: University of Minnesota		Team or Project Website: http://smallsat.umn.edu/exact-science
Student Leader Contact Information:		Faculty Advisor Contact Information:
Name:	Ricardo J. Saborio	Demoz Gebre-Egziabher
Department:	Aerospace Engineering & Mechanics	Aerospace Engineering & Mechanics
Mailing Address:	Department of Aerospace Engineering & Mechanics 110 Union St, SE 107 Akerman Hall	Department of Aerospace Engineering & Mechanics 110 Union St, SE 107 Akerman Hall
City, State, Zip code:	Minneapolis, MN, 55455	Minneapolis, MN 55455
e-mail:	sabor001@umn.edu	gebre@umn.edu
Office Telephone:	N/A	(612) 624 - 2305
Mobile Telephone:	(612) 417 - 9444	N/A

A. INTRODUCTION

The University of Minnesota (UMN) small satellite research group is a student-run organization, sponsored by the Minnesota Space Grant. Currently, one of the main focus of the group is building a pair of 3U CubeSats¹ that are slated for launch after 2018. The main payload of these CubeSats will be the most recent iteration of the CsI(Tl) Incident Energy Spectrometer (CITIES), based off the legacy Gamma Ray Incidence Detector (GRID) which has been tested on the High Altitude Student Platform (HASP) since 2010. HASP flight tests have been key to the development of the detector and have allowed for the testing of the unit and supporting hardware in space-like conditions [1, 2]. The unit itself has been designed and optimized to detect X-ray and Gamma-ray emissions from astrophysical sources including the sun and pulsars in the hopes of studying coronal mass ejections and developing a Guidance, Navigation & Control (GNC) sensor. The flight tests conducted thus far have led to multiple re-designs that have made their way into the most recent version of CITIES and consequently into the two CubeSat missions being developed by the group.

To support the testing and development efforts of CITIES and the two CubeSat missions, the group has developed the High Altitude X-ray Detector Testbed (HAXDT). HAXDT is a platform in the form factor of a 3U CubeSat and has been utilized by the team in previous years to flight-test detector prototypes and supporting hardware. HAXDT is designed to interface with the HASP adapter plate while still being able to mimic the operation of a small satellite, which in turn, allows for the testing of concepts utilized in CubeSat missions. HAXDT is effectively an engineering unit of a 3U CubeSat and features all the sensors and systems one would find on such a vehicle including a flight computer, a GPS receiver, an Inertial Measurement Unit (IMU), a communications radio, and an electrical power distribution system. The data logged from the payload is saved on-board in the flight computer or it can be sent down through radio to a ground station for processing during the flight.

1. Flight Objectives for 2018 Flight

On the 2018 HASP flight, HAXDT will host the most recent iteration of CITIES, currently being developed and tested by the University of Minnesota small satellite research group. CITIES has been 8 years in the making and consists of a tunable X-ray and Gamma-ray detector optimized for making accurate energy and time of arrival measurements. The sensor is designed to fulfill both a scientific and an engineering goal for its respective CubeSat missions. As a science instrument, the sensor will be used to study coronal mass ejections from the sun and characterize the high energy photons emitted by the events. On the other hand, as an engineering instrument, CITIES will be used as a position, navigation, and timing (PNT) sensor which derives its solution from x-ray and gamma-ray signals emitted by astrophysical sources [3].

In previous years, the HASP test flights have focused on testing and validating the performance of the detector but, as our work with CITIES starts to converge into a CubeSat, the team has to start focusing on validating the performance of the satellite's subsystems as well. Hence, this year's flight will focus on testing hardware and software components that are vital for the success of both

¹ The University of Minnesota is currently building two 3U CubeSats: EXACT (Experiment for X-ray Characterization and Timing) and SOCRATES (Signal of Opportunity CubeSat Ranging and Timing Experiments). Components for these CubeSats are being tested on HAXDT.

CubeSat missions. More specifically, the flight test will focus on validating the performance of our payload reprogramming abilities through radio. This is a key element in CubeSat missions since a significant number of first-time CubeSat missions fail due to problems faced with the flight computer once in orbit.

The HASP test flight would aid the team in understanding the effect of transmitting the reprogramming commands outside of a lab environment. Background noise and interference can be expected from our radio communications once in flight, therefore we have to make sure our system is robust enough to counteract these effects. Similarly, as a secondary science goal, the test flight will test the FPGA pre-processing abilities for raw detector data. This will involve testing the curve-fitting algorithm for the data, the internal storage performance, and the capabilities of the radio to relay raw data to the ground station. The HASP 2018 flight test will provide valuable insight on the subsystem's performance of HAXDT and will help in identifying potential points of failure for future CubeSat missions.

2. Experiment Description

HAXDT will be used as a passive observatory platform, once it is at altitude. Data collected from CITIES during the flight will be used to validate the performance of the sensor, onboard storage, and radio communications. The data relayed to the ground station will be compared to that stored on-board to verify proper operation of the subsystem.

During ascent, HAXDT will be reprogrammed through radio multiple times to perform different tasks while still in range with the ground station. The team will monitor the proper execution of these tasks through radio downlinking. In case of signal loss or incomplete commands being sent, the payload should revert to its initial software configuration. The goal is to individually re-program the flight computer and the FPGA.

In parallel, the team will be monitoring data from the RHESSI, SWIFT, and Fermi spacecraft during the duration of the flight. These spacecraft should detect any Gamma Ray Bursts (GRBs) or solar events that occur during the HASP 2018 flight. If a fortuitous event occurs during the float phase, both HAXDT and the previously mentioned spacecraft should detect it. The raw data recorded by HAXDT can then be compared to that of the in-orbit spacecraft to validate its accuracy.

B. PAYLOAD DESCRIPTION

A labeled 3D SolidWorks model of HAXDT is shown in **Figure 1**. HAXDT was designed to closely resemble a 3U CubeSat. In addition to CITIES, the rest of the payload, implemented as a PC/104 stack, includes the following components:

- A sixteen-channel (two-board) detector front end board.
- A BeagleBone Black rev. C microcomputer as the main flight computer.
- A Teensy 3.6 microprocessor used for pre-processing all sensor data except that from CITIES.
- A VN-100 IMU.
- A NovAtel OEM615 GNSS receiver and associated antenna.
- Power regulation, protection, and distribution circuit boards.
- An Analog-to-Digital Converter (ADC) board.
- A FreeWave MM2-T radio.
- A High-Voltage Power Supply (HVPS) board.

Power is provided to the payload by the HASP gondola and is regulated to 3.3V, 5V, and 12V DC outputs to power all payload systems. **Figure 2** below shows a high-level schematic of the hardware and respective connections that will be hosted by HAXDT on the 2018 HASP flight.

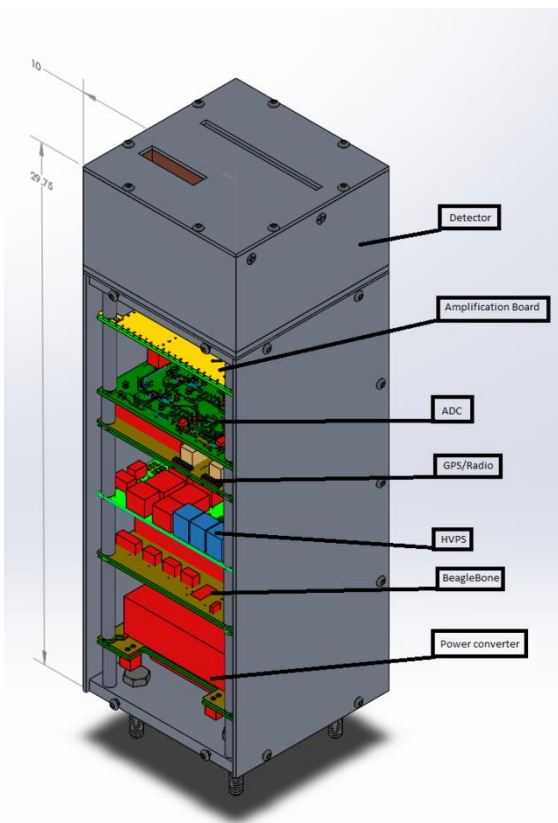

Figure 1: A 3D SolidWorks model of the 2018 iteration of HAXDT. Dimensions in centimeters.

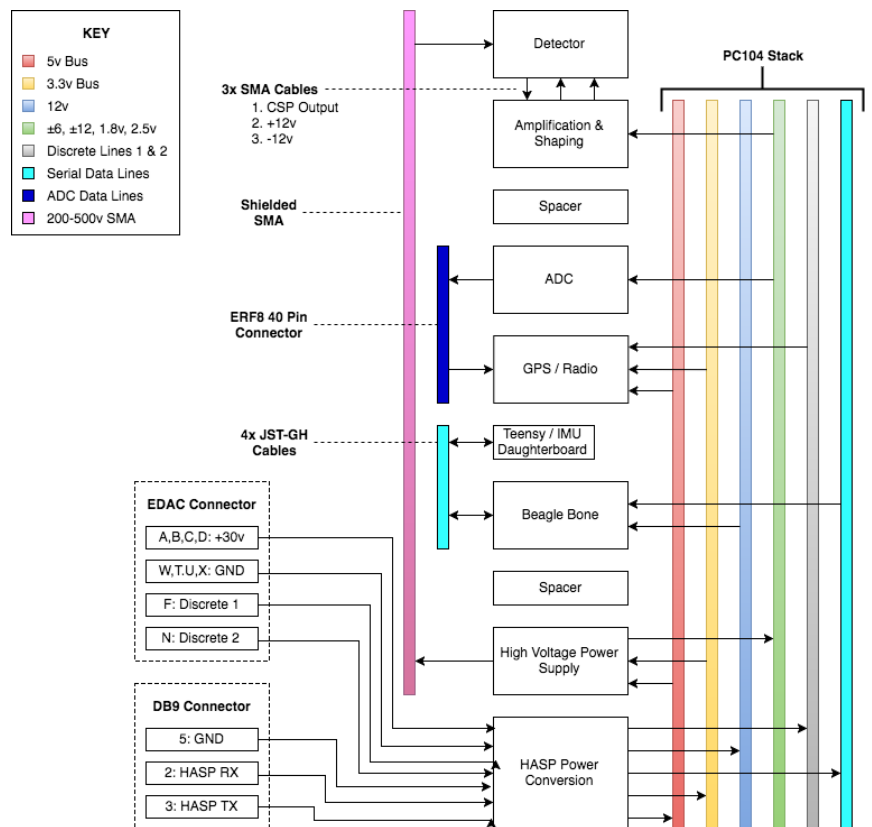

Figure 2: A high-level schematic of the hardware and respective connections for HAXDT. Note, the FPGA board is yet to be incorporated.

1. Sensor Payload

The sensor payload which will be flown on the HAXDT is CITIES. CITIES is a radiation detector which utilizes large scintillation crystals of CsI(Tl) as detection elements. Overall, CITIES follows a 1U CubeSat form factor so it is compact and easily integrated with the 3U missions of EXACT and SOCRATES. The scintillation crystals are enclosed in a custom designed aluminum housing structure which contains separate holding cavities for each crystal. Each crystal is of the same dimension, 7 mm x 7 mm x 40 mm, and therefore provides a total detection area of $\sim 44.8 \text{ cm}^2$ across all 16 detection channels. In order to restrict the energy regime that the detection elements are exposed to, a window is implemented which is covered with a thin layer of aluminum. This filters lower energy photons that are not of interest to either of the CubeSat missions for which CITIES is being designed. A single channel engineering prototype is shown in **Figure 3**. The top plate of the sensor package is omitted so the internal components can be seen in the figure.

Each CsI(Tl) crystal is coupled to a Silicon Photomultiplier (SiPM). The scintillation crystals emit photons in the visible spectrum after interacting with high energy photons. This interaction consists of an activator site, the thallium in the crystal, being excited past its band gap energy. After a short time, the activator will de-excite and emit photons corresponding to the activators band gap energy, called scintillation photons. These photons are of lower energy and are in the visible light spectrum as mentioned prior. The scintillated photons are absorbed by the SiPMs in our system which then convert this light into electric charge. This charge corresponds to a current pulse in the system which is processed by a series of processing electronics. This signal is later converted into a digital signal and processed by the FPGA where a curve is fit to the shape of the digital signal yielding specific parameters which correspond to the curve generated. One curve corresponds to one photon having made its way through the system. The FPGA also serves as a discriminator where only pulses which exceed a set energy level will be curve fit. The signal leaves the FPGA as a data packet containing the curve fitting parameters of interest as well as a time-stamp with microsecond precision.



Figure 3: A single channel engineering prototype of CITIES.

The dimensions chosen for the scintillation crystals was the result of an investigation looking into optimizing system performance while maintaining high detection area. EXACT and SOCRATES have different requirements for the detection system used, and it was found that the 7 mm x 7 mm x 40 mm dimensions yielded the best compromise performance while providing a large detection area. Each crystal functions independently from the others meaning that the system is the sum of sixteen smaller detectors. Eight of the outputs are handled by one FPGA and the remaining eight are handled by another FPGA, facilitating the high photon counts expected during large solar flares. All of the outputs are binned appropriately in time, giving a time history of the high energy events observed by CITIES.

The FPGAs are in charge of handling all science data. They sample the on-board ADCs, connected to CITIES, at a sampling rate of 5MHz. The sampling speed is fast enough to allow a good portion

of raw data to be obtained from the Gaussian shaping amplifier board. Given that the shaped pulses are known to be of a pseudo-Gaussian shape, an onboard curve fitting algorithm would be used to reduce large amounts of samples into two parameters that define the curve shape and a corresponding time stamp. This data is intended to be stored on an SD Card controlled by the FPGA that is available to the flight computer (described below) upon request.

CITIES is currently assessed to be at a Technology Readiness Level (TRL) of 4 based upon previous HASP flights and laboratory testing. According to NASA descriptions, a TRL of 4 is defined by “Component and/or breadboard validation in laboratory environment” [4]. Methods to increase the signal-to-noise ratio of the system have been implemented as well as shielding for the charge sensitive components. This takes into account the lessons learned from previous HASP flights and laboratory testing. A method to properly control the gain of the SiPMs (to minimize thermal and shot noise) has not yet been finalized but will be investigated during spring 2018.

2. Structure

The primary structure is composed of 6061-T6 aluminum in a 3U CubeSat configuration. The four side panels are 1/16” aluminum sheet. These panels are held together by four edge rails, which are joined by an aluminum plate at the bottom of the structure. The components are fastened together with size #4-40 self-locking 18-8 stainless steel socket head cap screws, and the bottom plate is affixed to the HASP Payload Mounting Plate with 1.25-inch long ATSM A307-20 bolts. The inside of the walls are covered with Kapton Tape to provide insulation and to add a protective layer to the electrostatic sensitive components of HAXDT. These structures, of course, do not need to conform to CubeSat standards. Additionally, this structure proved to be effective for thermal insulation in HASP 2017 and thus the no additional components are being added.

3. Computer and Data Logger

The central processing unit on the 2018 HAXDT payload will be a BeagleBone Black rev. C microcomputer with a “shield” consisting of a Teensy 3.6 microprocessor. The unit was chosen due to its size, low power consumption, space heritage, and legacy at the University of Minnesota as a Flight Computer for autonomous aerial vehicles. The BeagleBone handles all radio communications and stores all non-detector related data in the onboard memory. This sensor data includes GPS coordinates, attitude information, and temperature readings from onboard sensors. On the other hand, the Teensy 3.6 acts as a data aggregator by directly reading data from all sensors (except the payload), and pre-process it before relaying the data to the BeagleBone. The flight code in the BeagleBone is written in a combination of Python and C, and it is based off the Goldy 3.0 flight computer developed by the University of Minnesota’s Unmanned Aerial Vehicle (UAV) Lab. Timing in the flight computer is synchronized with GPS time. The GPS one pulse-per-second (PPS) signal is used to discipline all onboard oscillators, thereby, allowing for hardware-based time synchronization.

4. System Operation

Once HASP operations begin, power will be provided to HAXDT and the payload will remain on for the duration of the flight. The UMN team will be able to use radio to send commands to alter the states of the state machine. These commands can dictate whether the payload is collecting data, transmitting data, or entering reprogramming mode. Additionally, the radio can be utilized to alter the software onboard the payload, a component that will be essential for the engineering test performed during the ascent phase of the flight. These commands do not rely on the HASP systems for uplink since they are done through the communications subsystem of HAXDT using the FreeWave MM2-T radio. Scientific data will be stored on-board and copies of this data will also be sent through radio for processing during flight. The serial downlink provided by HASP will be used to monitor payload health by sending the data packets, outlined on **Table 3** below, once every second. If data collection is not proceeding as expected, then a request to power cycle the payload will be made.

The data generated and processed by HAXDT will be downlinked to the UMN team's ground station using a 915 MHz frequency which falls within the amateur band. In the event our antenna on the payload interferes with the gondola systems or other payload, a discrete line will be utilized to shut down the radio independently of the payload via a relay switch.

C. TEAM STRUCTURE AND MANAGEMENT

HAXDT/HASP is one of the activities in the UMN CubeSat research group. The group is led by a Program Manager or PM (**Jenna Burgett**, sophomore in Physics) and a Chief Engineer or CE (**Abigail Valero**, junior in Aerospace Engineering). The PM and CE report to the two faculty advisers (**Dr. Demoz Gebre-Egziabher** and **Dr. Lindsay Glesener**) that supervise the CubeSat research group.

Reporting to the PM and CE is the HAXDT/HASP project manager (**Ricardo Saborio**, junior in Aerospace Engineering). The HAXDT/HASP project manager will be responsible for team management, monthly report submission and teleconferences, and hardware and material procurement. Several undergraduate students who worked on the 2017 payload will continue their contribution for the 2018 project cycle. **Maxwell Yurs** will lead the development of CITIES and integration with the payload. **Andrew Mosin** will lead the flight computer and software development. **Gaurav Manda** will lead the development and integration of the FPGA. **Aaron Nightingale** will lead the design of the payload's circuitry. **Melissa Nightingale** will lead the design and fabrication of the payload structure. **Lukas Zumwalt** will lead the development of the communications subsystem.

Trevor Knuth is a doctoral candidate in physics and will serve as the technical adviser for the payload design team. **Joel Runnels**, another doctoral candidate whose research is examining the design of algorithms for GRB-based ranging and timing, will be used as a consultant to help Mr. Saborio and his team. Additional undergraduate participants may be recruited to assist the team leads in payload operation and development.

Dr. James Flaten is supervisor for the University of Minnesota ballooning team and provides expert advice in balloon flight operations. **Dr. Suneel Sheikh** is the CEO of ASTER Labs, Inc. and an expert in X-ray navigation. Dr. Sheikh provides ongoing consultation in the development of this payload system.

Students			
Jenna Burgett	Project Manager	University of Minnesota 107 Akerman Hall 110 Union St. SE Minneapolis, MN 55455	burge241@umn.edu
Ricardo Saborio	HASP Lead	University of Minnesota 107 Akerman Hall 110 Union St. SE Minneapolis, MN 55455	sabor001@umn.edu
Abigail Valero	Chief Engineer	University of Minnesota 107 Akerman Hall 110 Union St. SE Minneapolis, MN 55455	valer044@umn.edu
Maxwell Yurs	Detector Lead	University of Minnesota 107 Akerman Hall 110 Union St. SE Minneapolis, MN 55455	yursx002@umn.edu
Andrew Mosin	Flight Computer Lead	University of Minnesota 107 Akerman Hall 110 Union St. SE Minneapolis, MN 55455	mosin005@umn.edu
Gaurav Manda	FPGA Lead	University of Minnesota 107 Akerman Hall 110 Union St. SE Minneapolis, MN 55455	manda063@umn.edu
Aaron Nightingale	Electronics Lead	University of Minnesota 107 Akerman Hall 110 Union St. SE Minneapolis, MN 55455	night030@umn.edu
Melissa Nightingale	Structures Lead	University of Minnesota 107 Akerman Hall 110 Union St. SE Minneapolis, MN 55455	night033@umn.edu
Luke Zumwalt	Communications Lead	University of Minnesota 107 Akerman Hall 110 Union St. SE Minneapolis, MN 55455	zumwa020@umn.edu
Joel Runnels	Technical Consultant	University of Minnesota 107 Akerman Hall 110 Union St. SE Minneapolis, MN 55455	runne010@umn.edu
Faculty Advisors			
Dr. Demoz Gebre-Egziabher	Principal Investigator	University of Minnesota 107 Akerman Hall 110 Union St. SE Minneapolis, MN 55455	gebre@aem.umn.edu 612-624-2305
Dr. James Flaten	Assistant Director, Minnesota Space Grant Consortium	University of Minnesota 107 Akerman Hall 110 Union St. SE Minneapolis, MN 55455	flaten@aem.umn.edu 612-626-9295
Industry Partners			
Dr. Suneel Sheikh	CEO and Chief Research Scientist	ASTER Labs 155 East Owasso Lane Shoreview, MN 55126	sheikh@asterlabs.com 651-484-2084

Table 1. Mailing addresses, affiliations and contact information of key personnel.

It is anticipated that between three and six students will participate in integration at Columbia Scientific Balloon Facility (CSBF) and possibly three students will participate in flight operations at Ft. Sumner. **Table 2** below shows the anticipated timeline and milestones for this project (milestones in bold).

Month of 2018	Description of Work
January	Undergraduate recruitment and training.
February – March	Develop reprogramming code.
March – April	Final flight system design and integration with CITIES. Fabrication of payload structure. Finalize software development.
April 27	Preliminary PSIP document deadline.
April - May	Full systems integration and testing.
June	Final assembly and testing.
June 29	Final PSIP document due.
July	Finalize flight operations plan. Verify all systems go.
July 26	Final FLOP document due.
July 23 – July 27	Student payload integration at CSBF.
August	Correct unforeseen issues, if any.
September 1 – September 5	HASP flight preparation.
September 7	Launch. Parse and extract flight data upon payload's return to UMN.
October	Analyze results and begin science report.
November	Complete data analysis and final report.
December 7	Final Report deadline.

Table 2. Preliminary 2018 HASP timeline for the UMN team.

D. PAYLOAD DATA, POWER AND MASS SPECIFICATIONS

There will be one discrete line implemented to control the radio power. In the event of interference, no uplink will be required on our end. However, some downlink bandwidth will be required for system health monitoring. The serial link will be connected at 1200 baud using 8 data bits, no parity, and 1 stop bit as described in the HASP Student Payload Interface Manual. The serial downlink traffic from HAXDT will be 216 bps (the 27 byte packet outline in **Table 3** below plus serial framing bits) sent over the 1200 baud connection. The data transfer will occur at a frequency of 1 Hz.

The data rate and/or packet structure may change during the development of the payload to include metric, which will be used to determine proper operation of all payload components in real time. Data regarding success of reprogramming attempts will also be included. Any such changes will be detailed in future documentation. If the data received via the downlink indicates that data collection is not proceeding as planned, then a power on/power off command will be requested. Thus, the only discrete line required is the default line that powers the payload on and off.

No analog downlink channels are expected to be utilized for the 2018 HAXDT payload.

Byte	Title	Description
1-2	Header	Indicates beginning of data record
3-6	Latitude	Current latitude of the payload in degrees
7-10	Longitude	Current longitude of the payload in degrees
11-14	Height	Current height of the payload in meters
15-18	Detector Bytes	Number of bytes stored of raw detector data
19	Temperature	Temperature of onboard electrical components in Celsius
20-22	UTC Time	UTC Time giving hours, minutes, and seconds into the day
23	Detector Status	8 bits used for detector status flags
24-25	Error Word	16 bits used for error flags
26-27	Footer	Indicates end of complete data record

Table 3. Preliminary HAXDT downlink packet structure.

Anticipated procedures at the Student Payload Integration include testing that HAXDT interface with the HASP gondola is configured properly via the EDAC 516 connector; that power is being delivered and does not exceed the allowed current draw; and that the payload collects, downlinks, and stores data without issue. Additionally, reprogramming abilities for the payload will be tested on campus at UMN and once again in CSBF to verify proper operation. If the payload passes these tests, then it will be subjected to the planned thermal/vacuum testing. Assuming success at integration, procedures at flight operations are anticipated to consist solely of making sure the payload is connected properly, power ups without issue, and that communication with the on-board radio is established. It should be noted that HAXDT will undergo thorough integration testing at the University of Minnesota before integration.

1. Payload Mass and Power Budget

The payload will use the EDAC 516 connector to provide power to all systems by regulating the voltage and distributing it according to each system's power requirements as outlined in **Figure 2**. In addition, **Table 4** and **Table 5** outline the power and mass budgets for the payload components. Note that the FPGA boards have not yet been included in both budgets. That being said, regardless of the design changes which may yet to be made (adding additional components like the FPGA), the mass and power specifications of the payload will remain within the limits of 3kg and 500mA for the small payload classification.

As can be seen, in our worst case—a.k.a most power required—scenario, and considering a 10% uncertainty in prediction, our payload will draw 464 mA from the 30 V HASP supply. This is still within HASP requirements of a maximum current of 500 mA drawn from the supply.

Structural Components		
Back Wall	0.051 kg	Estimated
Left Wall	0.128 kg	Estimated
Right Wall	0.128 kg	Estimated
Access Panel	0.123 kg	Estimated
Bottom Plate	0.155 kg	Estimated
Attachment Hardware	0.007 kg	Estimated
Detector Components		
Top Plate	0.050 kg	Estimated
Crystal	0.015 kg	Estimated
Cork Insert	0.015 kg	Estimated
Tray	0.085 kg	Estimated
Middle Housing	0.274 kg	Estimated
APD Circuit Board	0.010 kg	Estimated
Bottom Plate	0.082 kg	Estimated
Ceramic Plate	0.028 kg	Estimated
Attachment Plate	0.147 kg	Estimated
Attachment Hardware	0.007 kg	Estimated
Cork Stopper, Spring, and Aluminum Blanketing	< 0.001 kg	Estimated
Electrical Components		
Amp/Shaping	0.043 kg	Measured
ADC	0.049 kg	Estimated
High Voltage Power Supply (HVPS)	0.096 kg	Estimated
GPS/Radio	0.087kg	Measured
BeagleBone and Teensy	0.114 kg	Estimated
Power Regulators	0.176 kg	Measured
Total	1.871 ± 0.187 kg	Calculated

Table 4. Preliminary mass budget for the 2018 HAXDT payload. An uncertainty of 10% was assumed for all of the components. It can be observed that even in our worst case scenario our payload will be well below the 3kg weight limit.

	Initialize	Transmit	Low Power	Tumbling	Data Read	Data Write
	Percent On	Percent On	Percent On	Percent On	Percent On	Percent On
Radio & Antenna RX	100	100	100	100	100	100
Radio & Antenna TX	100	100	10	10	10	10
GPS	100	100	100	100	0	0
Detector, Shaper, ADC, HVPS	100	0	0	0	100	0
	100	0	0	0	100	0
Flight Computer	100	100	100	100	100	100
Net Power Required (W):	12.654	10.254	5.637	5.637	6.237	3.837
Power Required + 10% Uncertainty (W):	13.9194	11.2794	6.2007	6.2007	6.8607	4.2207
Current at Maximum Power Requirement (mA):	463.98	375.98	206.69	206.69	228.69	140.69

Table 5. Preliminary power budget for the 2018 HAXDT payload.

2. Payload Location and Orientation

Considering the fact that HAXDT contains an on-board IMU and GPS receiver, it will be possible to determine detector pointing from data processing after the flight. These will include position, velocity, and orientation states of the payload. Hence, there are no pointing requirements for the evaluations of the CITIES sensor.

E. MECHANICAL DRAWING OF HAXDT STRUCTURE

The figures below show the mechanical drawings of the bottom plate, side panels, and edge rails of the 3U CubeSat structure. A mechanical drawing of the full assembly of HAXDT and HASP plate interface have been included as well.

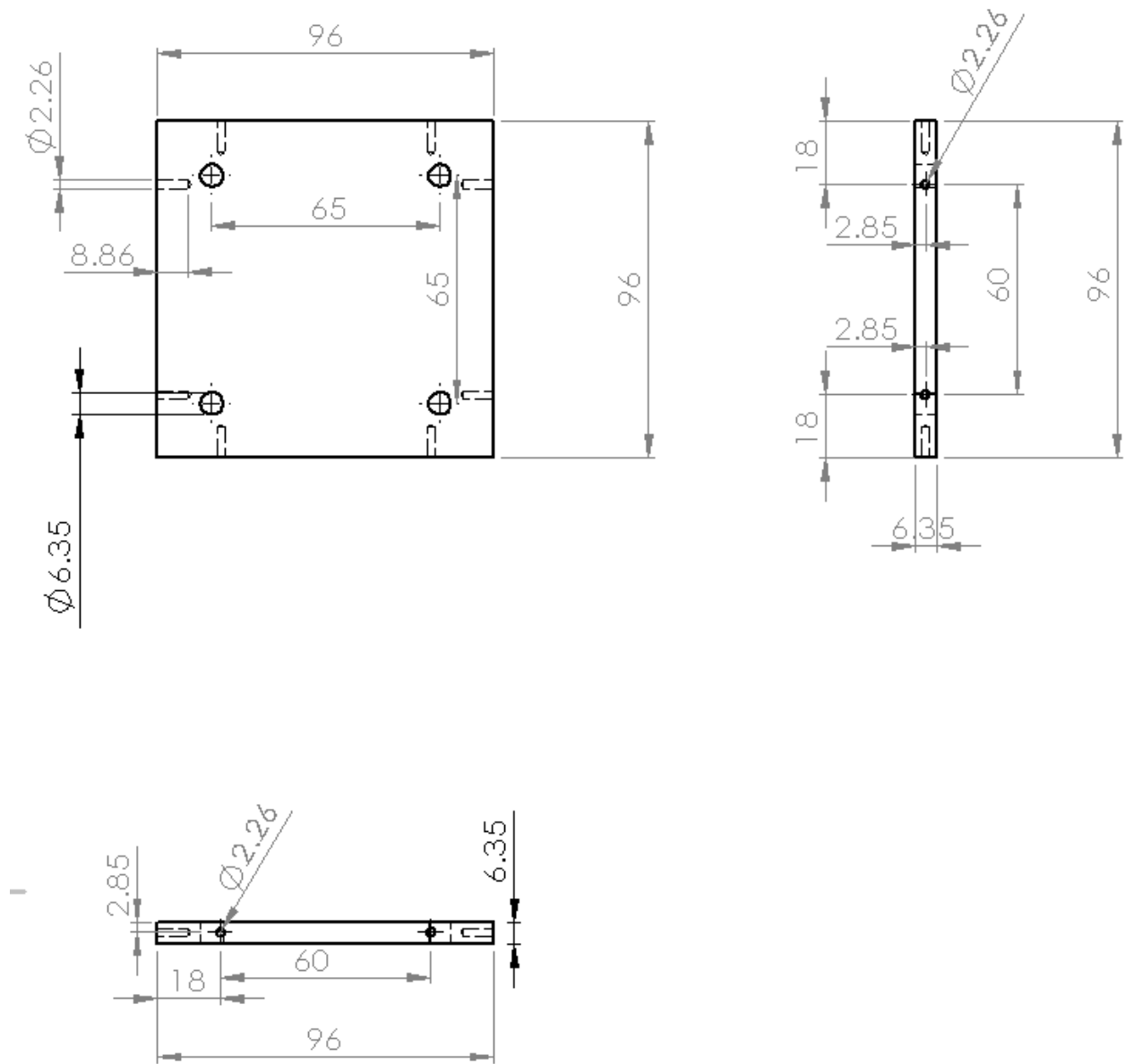

Figure 4. Mechanical drawing of the bottom plate of the structure with dimensions in millimeters. This plate attaches to the HASP mounting plate using 1/4-inch diameter bolts and serves as the anchor for the structural walls (see Figures 5, 6, 7 respectively).

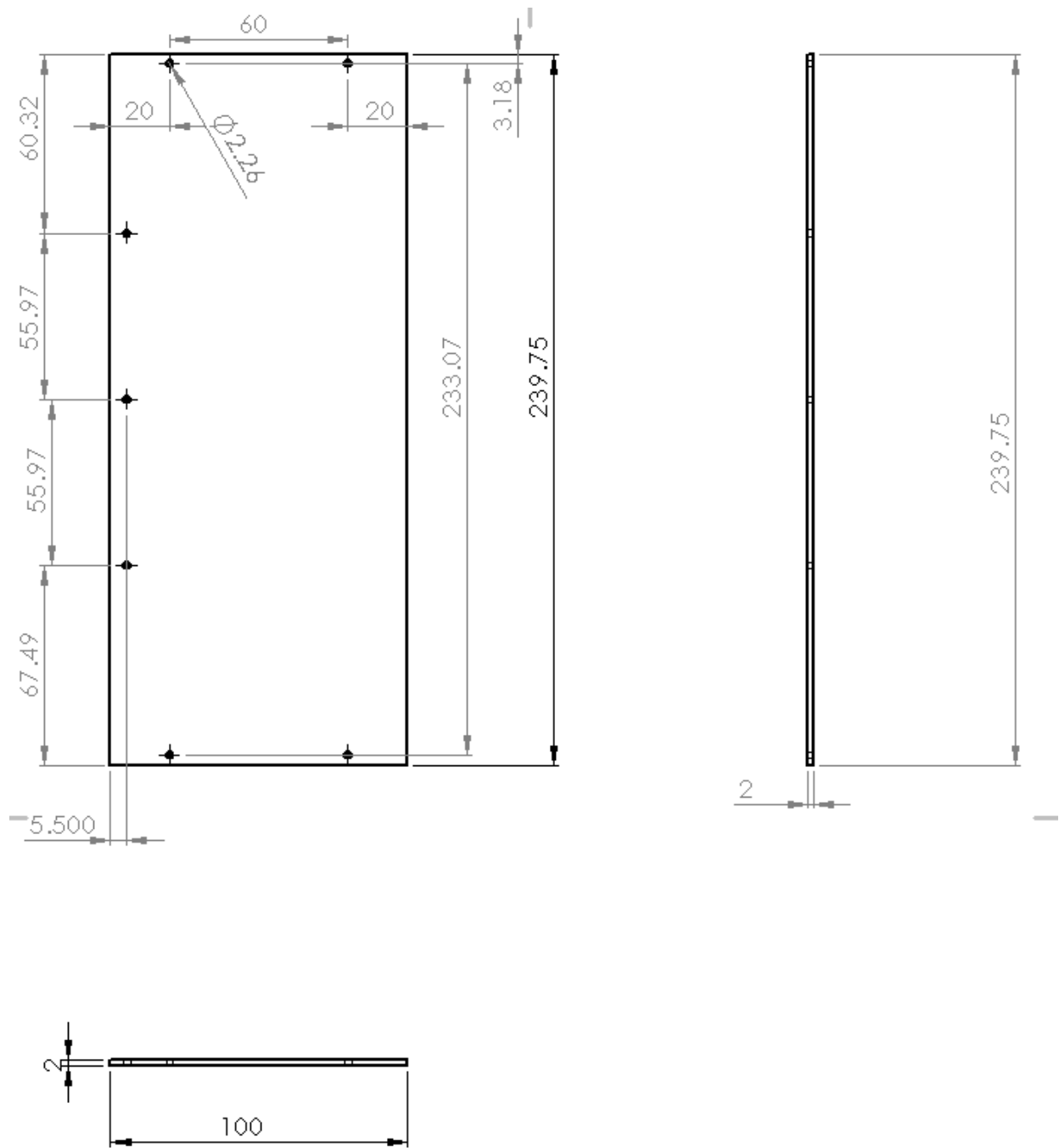

Figure 5. Mechanical drawing of the left and right load bearing structural walls with dimensions in millimeters. The walls will have an outer cross section of 10x10 cm in order to simulate CubeSat constraints.

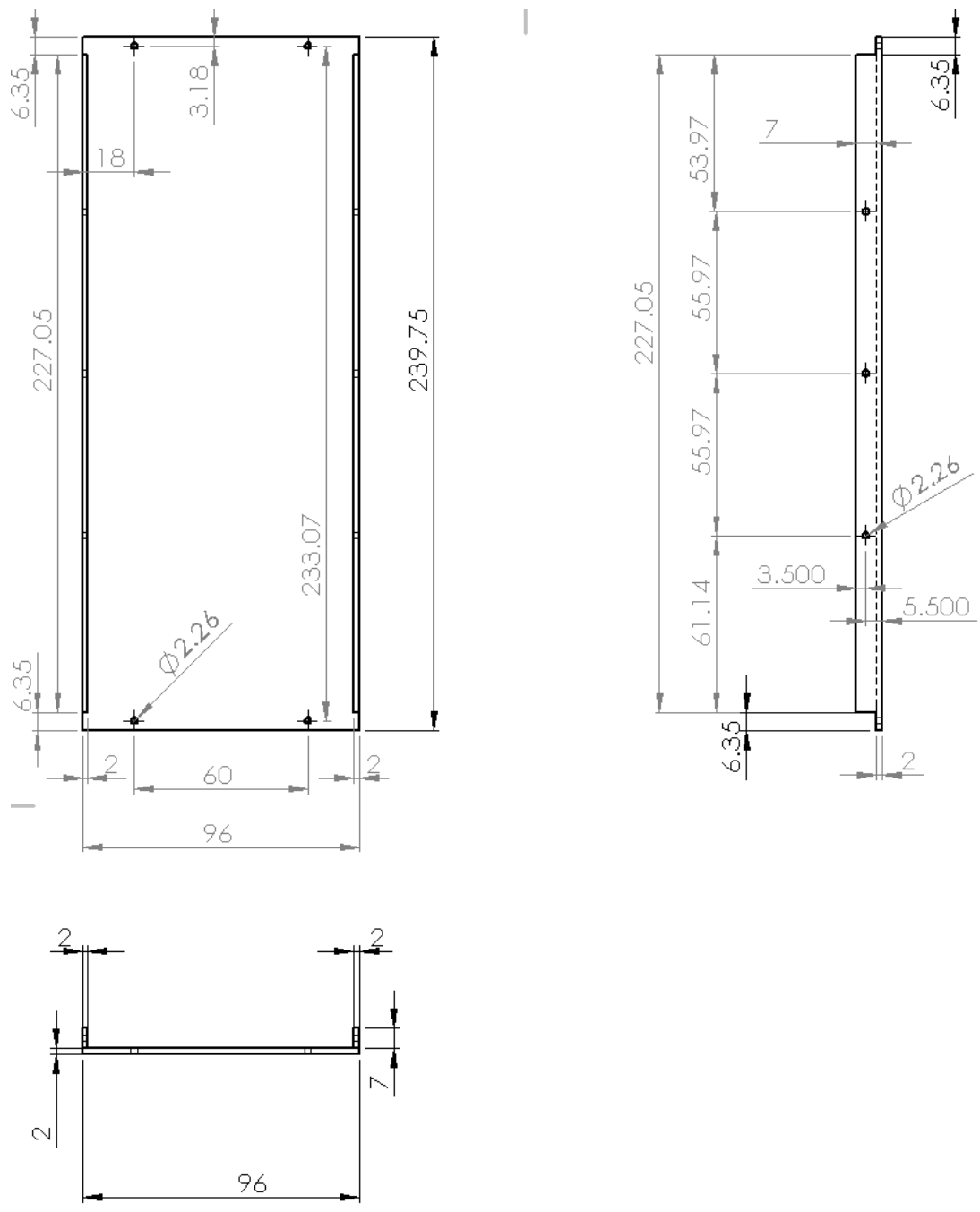

Figure 6. Mechanical drawing of the back structural wall for the 2018 payload, with dimensions in millimeters.

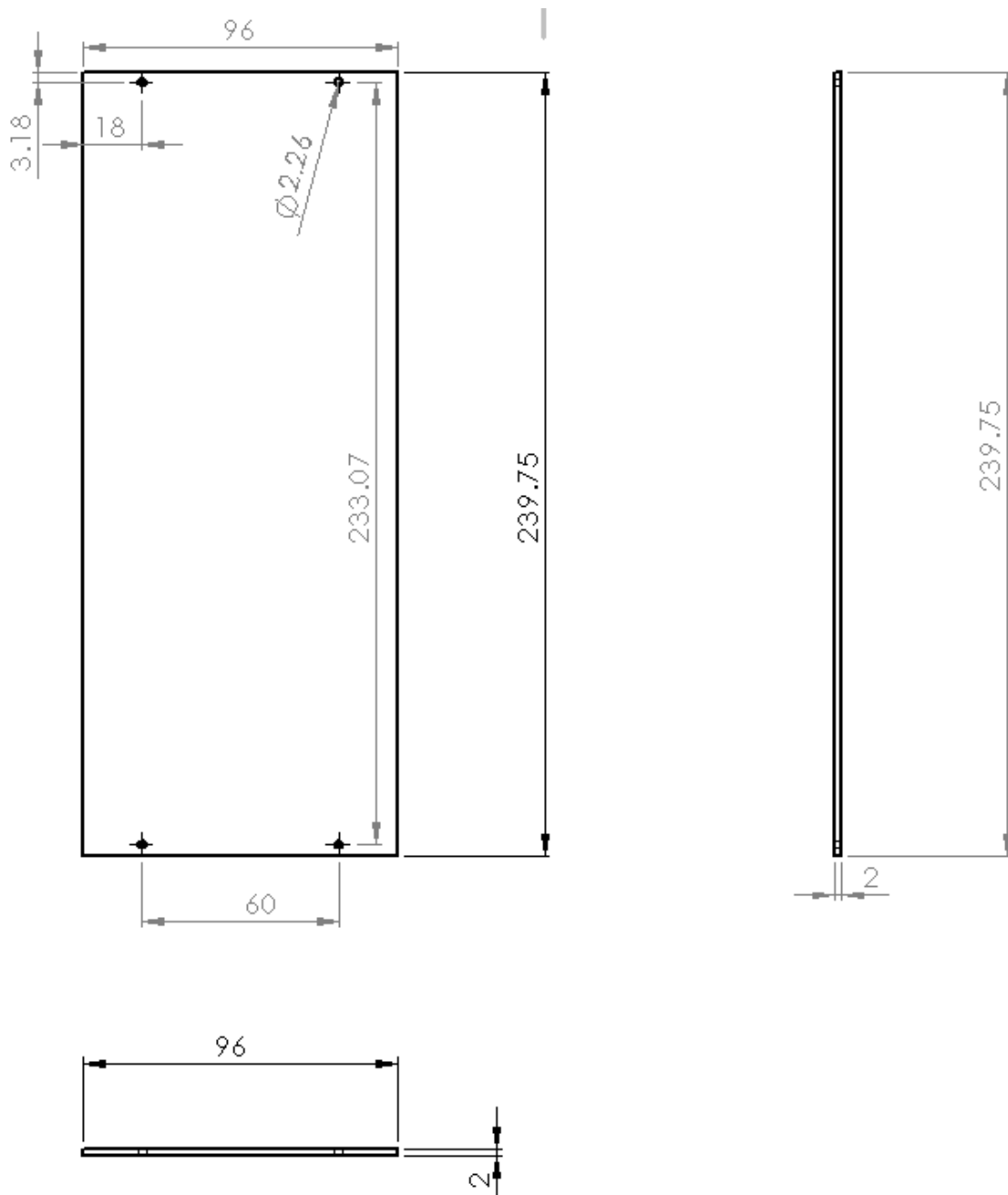

Figure 7. Mechanical drawing of the front structural wall for the 2018 payload with dimensions in millimeters. This is going to be the main access panel for our payload. The cut-out for the connections to the Radio antenna, GPS antenna, and EDAC connector are yet to be added.

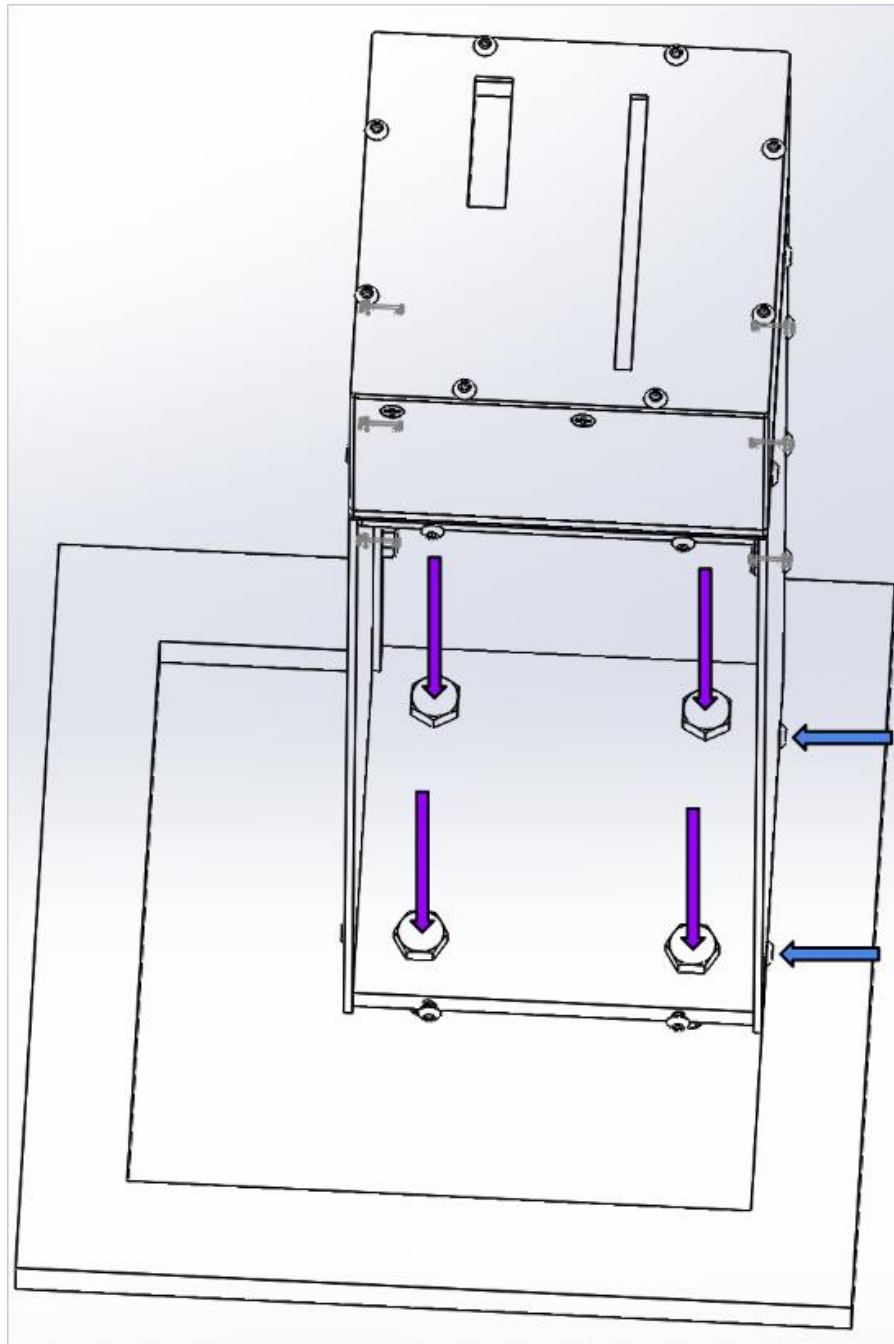

Figure 8. Mechanical drawing of the structural walls (Figures 5, 6, and 7) attached to the bottom plate (Figure 4) via screws located at the blue arrows going horizontal to the HASP mounting plate. There will be 2 of these screws on each side of the structural walls. The bottom plate is attached to the HASP mounting plate by 4 1/4" diameter bolts shown by the purple arrows going perpendicular.

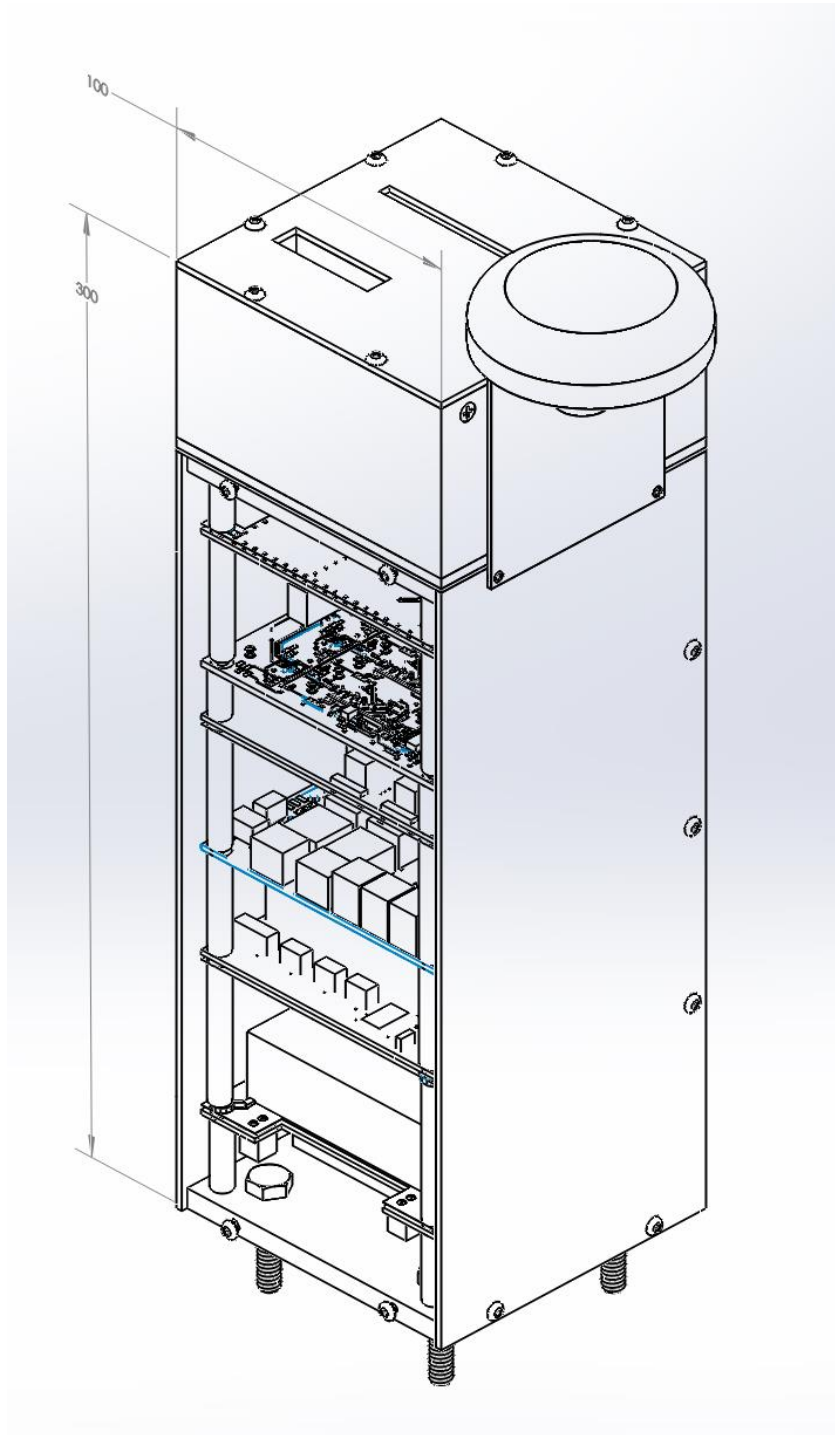

Figure 9. The previous mechanical drawing depicts the final payload assembly with the GPS antenna mount included.

F. REFERENCES

- [1] P. T. Doyle, The Development of a Simulator System and Hardware Test Bed for Deep Space X-ray Navigation, vol. Master of Science Thesis, Minneapolis, MN: Department of Aerospace Engineering and Mechanics, University of Minnesota, Twin Cities Campus, 2012.

- [2] P. T. Doyle, D. Gebre-Egziabher and S. I. Sheikh, "The Use of Small X-ray Detectors For Deep Space Relative Navigation," in SPIE Nanophotonics and Macrophotonics for Space Environments, San Diego, 2012.

- [3] C. S. Hisamoto and S. I. Sheikh, "Spacecraft Navigation Using Celestial Gamma-Ray Sources," Journal of Guidance, Control, and Dynamics, vol. 38, pp. 1765-1774, 2015.

- [4] "Technology Readiness Level." Nasa.gov, NASA, www.nasa.gov/sites/default/files/trl.png.