



HASP Payload Specification and Integration Plan

Payload Title: Measurement of Ozone Profile in the Stratosphere Using Nanocrystalline Sensor Arrays

Payload Class: Small Large (circle one)

Payload ID: 7

Institution: University of North Dakota and University of North Florida
Marissa Saad (student)

Contact Name: Dr. Ronald Fevig and Dr. Nirmal Patel
Marissa: (617) 462-0610,

Contact Phone: Ron: (520) 820-3440, Nirmal: (904) 200-2855
marissa.saad@my.und.edu,

Contact E-mail: or rfevig@aero.und.edu, npatel@unf.edu

Submit Date: 12/16/2011

I. Mechanical Specifications:

A. Measured weight of the payload (not including payload plate)

Sr.	Item	Mass (Grams)	Uncertainty (Grams)	Dimension (mm)	Uncertainty (mm)
Sensors Box					
1	Metal Box for sensors	110.0	2.0	127.0x56.0x56.0	0.1x0.1x0.1
2	Sensor Circuit board	14.0	0.1	130.0x42.0x2.00	
3	24 Sensors slide	4.6	0.2	75 x 25 x1	
4	6 binder clips	8.4	0.5		
5	Fan with wires	12.0	1.0		
6	25 pin cable	35.0	2.0		
7	heater with wire	1.6	0.1		
8	Temperature sensor	3.0	0.1		
11	Screws and nuts	10.0	1.0		
12	LED	5.0	0.1		
13	extra washers, etc	10.0	1.0		
Total mass of sensors box(1 to13)		213.6	7.9		
Payload Body		1591.0	10.0	296x 141x141	2x1x1
Base Mounting Plate & Cables		560.0	1.0		
Circuit board with components		185.0	5.0	Expected	
Total mass of the payload		2549.6	23.9		



HASP Payload Specification and Integration Plan

- B. Provide a mechanical drawing detailing the major components of your payload and specifically how your payload is attached to the payload mounting plate (**in meters**)

The 2008 payload body was built using foam. The payload was not easily opened once it was closed. That was the main issue. The 2009 payload body was built using PVC sheet and aluminum frame. It was easy for us to open and close the payload. The 2009 payload body was mechanically stable and thermally insulated compared to the 2008 payload. The 2012 payload body is almost similar to the 2010 payload. We are trying to reduce the mass of payload.

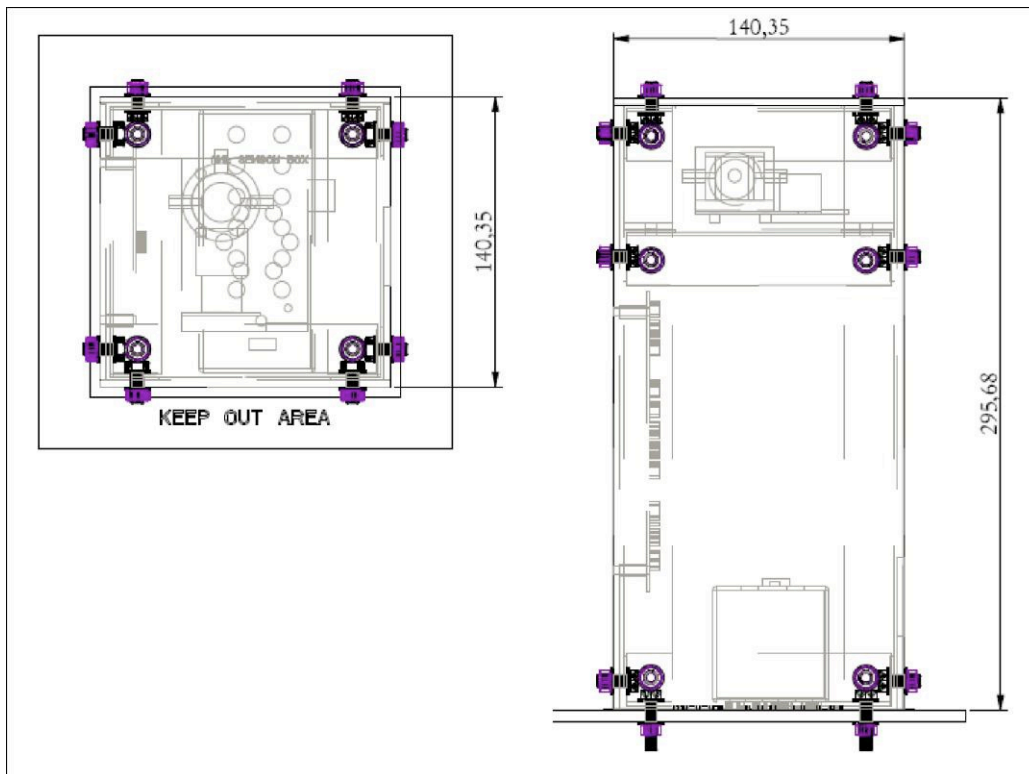



HASP Payload Specification and Integration Plan

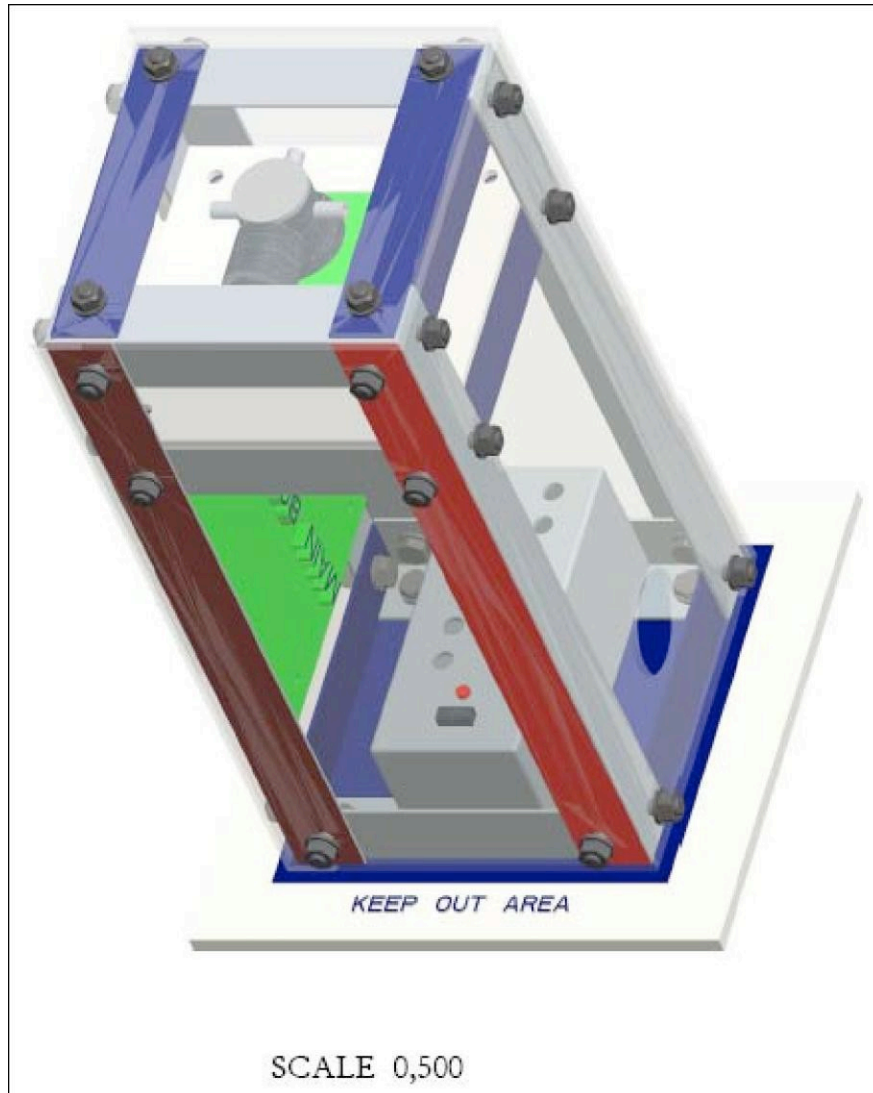

- C. If you are flying anything that is potentially hazardous to HASP or the ground crew before or after launch, please supply all documentation provided with the hazardous components (i.e. pressurized containers, radioactive material, projectiles, rockets...)

N/A

- D. Other relevant mechanical information

The payload structure comprises of Al 6061 angle frames and PVC walls 1/8" thick. The PVC plates are attached to the Al 6061 framework by M6 bolt, washer and nut assemblies. The footprint of the payload is limited to less than 30 cm in height (~29cm), and is ~15cm x 15cm. The complete payload assembly will be mounted on the HASP mounting plate with 4 M6 bolt, washer, and nut assemblies.



HASP Payload Specification and Integration Plan

One of the PVC walls have the PCB mounted from inside. A sensor array system box will fit on the one of the side PVC wall so that sensor array face outside of the payload and expose to ozone.

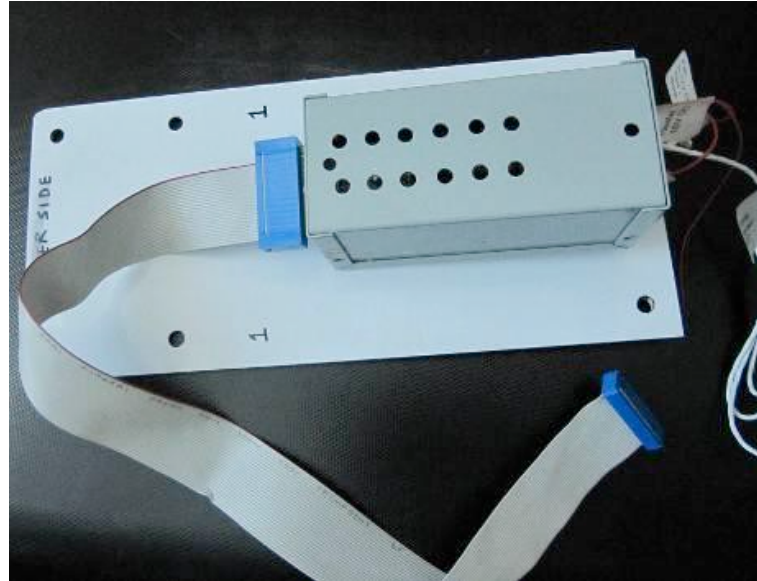

Inside view

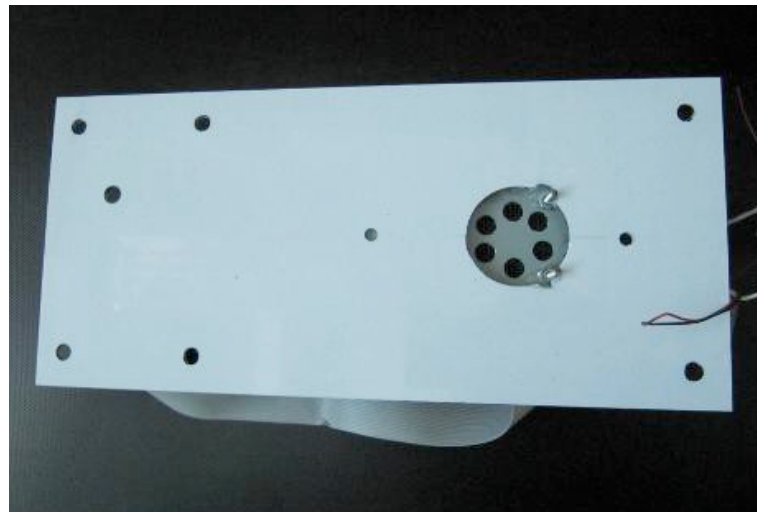

Out side view



HASP Payload Specification and Integration Plan

The complete payload assembly will be wrapped up with multiple layers of Mylar (space) blanket for insulation. The insulation will have reflective silver surface facing inside to assure maximum thermal insulation.

Please refer the attached stress analysis images of deformation and stress gradient satisfying 10 g vertical and 5 g horizontal accelerations.

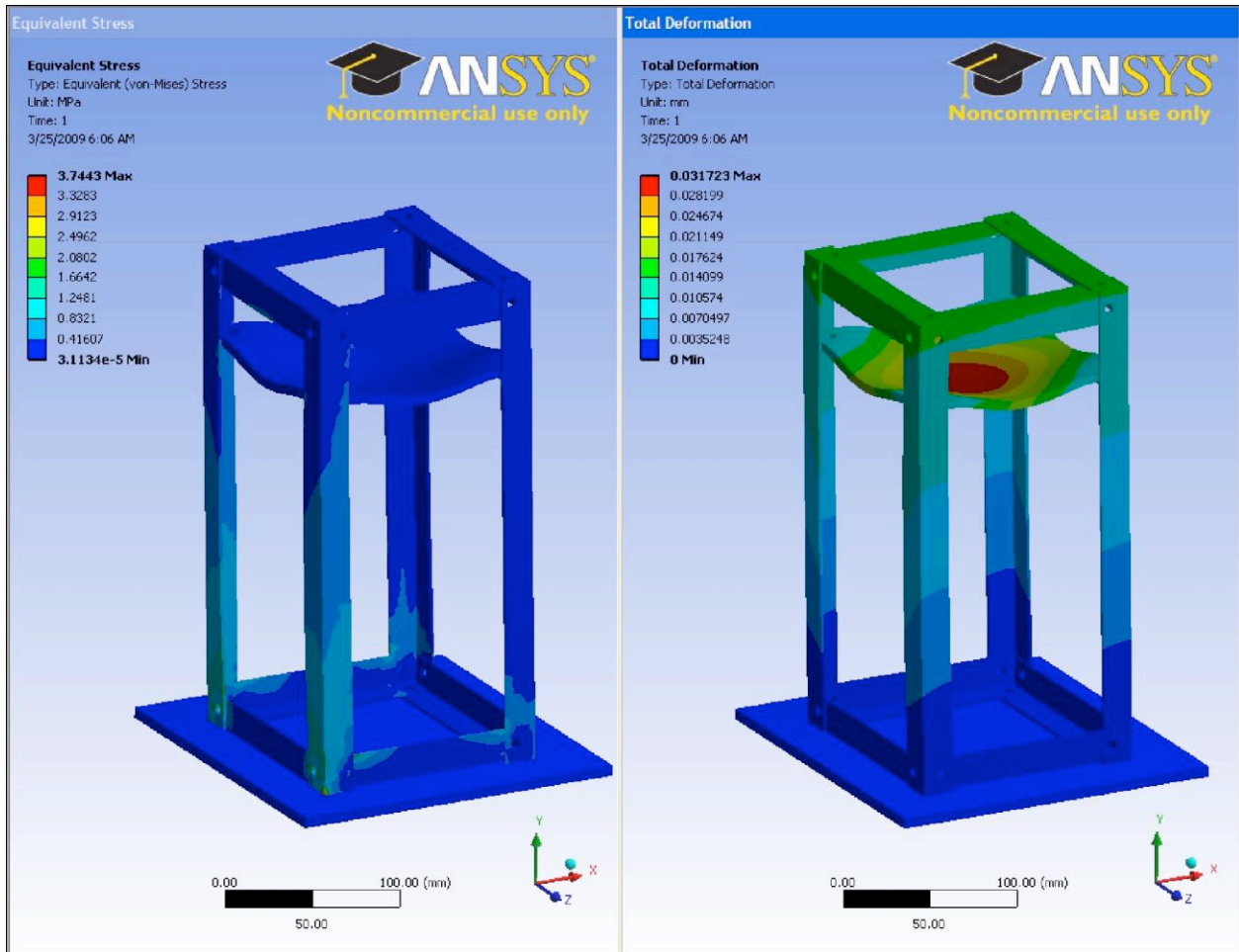



HASP Payload Specification and Integration Plan

II. Power Specifications:

A. Measured current draw at 30 VDC

0.5 A (measured system max)

0.040 (heater off, all other systems functioning)

B. If HASP is providing power to your payload, provide a power system wiring diagram starting from pins on the student payload interface plate EDAC 516 connector through your power conversion to the voltages required by your subsystems.

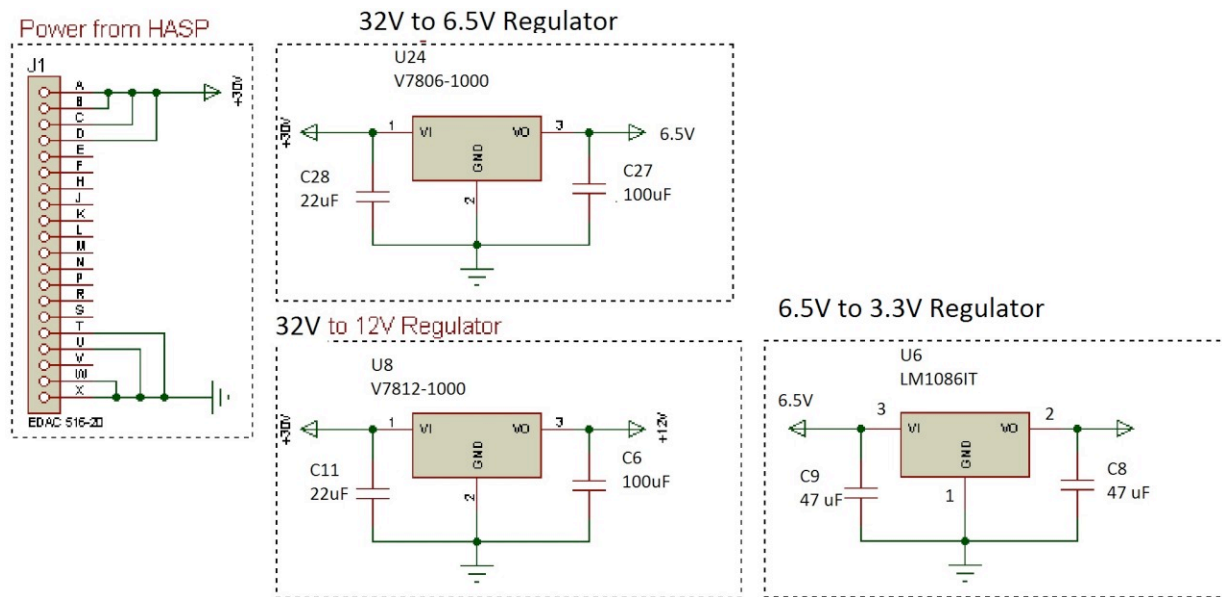

C. Other relevant power information. None



HASP Payload Specification and Integration Plan

III. Downlink Telemetry Specifications:

- A. Serial data downlink format: Stream **Packetized**
- B. Approximate serial downlink rate (in bits per second)
- C. Specify your serial data record including record length and information contained in each record byte.

4 bytes for UTC time (unsigned long integer format, fractional seconds truncated)

4 bytes for MLS altitude (unsigned long integer format, meters)

24 x 2 bytes for filtered ozone data (unsigned integer format, scaled voltage corresponding to ozone ppm)

6 x 2 bytes for onboard system voltage measurements

1 byte for system temperature in degrees C

1 byte for system status (heater on/off, fan on/off, flash read/write error)

This data is captured once every 10 seconds and then all the data from last downlink is then sent. This leads to a maximum of 910 data bytes.

This data will be sent according to Table 3 in the HASP Interface manual ie:

BYTE	Bits	Description
1	1	Data Record
2-3	0-31	Record Size
4	0-8	Least significant 8 bits of record checksum
5-915 (max)		Data as outlined above

Provided the onboard data logging storage element fails during flight all data from downlink to the next downlink will be stored in the microcontroller's on board EERPOM for downlink

- D. Number of analog channels being used: **0**
- E. If analog channels are being used, what are they being used for? **N/A**
- F. Number of discrete lines being used: **0**
- G. If discrete lines are being used what are they being used for? **N/A**
- H. Are there any on-board transmitters? If so, list the frequencies being used and the transmitted power. **No**



HASP Payload Specification and Integration Plan

I. Other relevant downlink telemetry information.

IV. Uplink Commanding Specifications:

- A. Command uplink capability required: Yes No
- B. If so, will commands be up linked in regular intervals: Yes No
- C. How many commands do you expect to uplink during the flight (can be an absolute number or a rate, i.e. *n commands per hour*)

1-2 commands per hour maximum.

D. Provide a table of all of the commands that you will be up linking to your payload.

Byte	Hex Value	Description
1	0x01	SOH
2	0x02	STX
3	0x71, 0x73	0x71 – Checksum for 0x31, 0x73 – Checksum for 0x33
4	0x31, 0x33	0x31 – System Reset, 0x33 – Change fan state
5	0x03	ETX
6	0x0D	CR
7	0x0A	LF

E. Are there any on-board receivers? If so, list the frequencies being used.

No

F. Other relevant uplink commanding information. **None**

G. **Request:** Team is requesting the HASP to provide the GPS strings from the gondola every 10 seconds.

V. Integration and Logistics

A. Date and Time of your arrival for integration:

Will be available at anytime on or before Monday August 2nd

B. Approximate amount of time required for integration:

~3 to 4 hrs.

C. Name of the integration team leader:

Marissa Saad



HASP Payload Specification and Integration Plan

D. Email address of the integration team

Marissa Saad, marissa.saad@my.und.edu,
Jason Saredy, sarj00007@unf.edu

E. List ALL integration participants (first and last names) who will be present for integration with their email addresses:

Dr. Ron Fevig, rfevig@aero.und.edu
Nirmalkumar Patel, npatel@unf.edu
Marissa Saad, marissa.saad@my.und.edu (tentative)
Jonathan W. Snarr, wade@speedhut.com (tentative)

F. Define a successful integration of your payload:

Payload successfully mounts to platform, both mechanically and electronically. Payload successfully performs a sensor/communication check, and systems health checks to ensure proper data/headers formatting. After an initial test sequences a steady 1 Hz led flashing indicates a sound system. After initial system testing is complete the system will successfully packet and send data to HASP computer and ground station computer will decipher and provides data plots of ozone concentration in real-time during final preflight testing (thermal vacuum testing). No commanding during TVAC is necessary other than a software reset of the system. If by chance there is a component failure of the system the hardware block will be examined for causes of failure, reworked, and tested prior to subsection the system to the TVAC test again.

G. List all expected integration steps:

a) **Successfully interface the payload to platform.**

- a. **Mount to platform**
- b. **Interface with power system**
- c. **The software for the 2012 flight has been completely revamped from that of 2009. All software has been tested thoroughly in the embedded system that will be tested in the TVAC. All commands have been checked and found to function. Data storage, packaging, and downlinking has also found to function. As listed in section F all software functions will again be tested in TVAC including but not limited to:**

**System Reset
Data packaging
Data downlinking**



HASP Payload Specification and Integration Plan

System status checks via downlinked status byte

Fan commands

Real time data streaming of Sensor readings, system voltages, and ambient temperature.

H. List all checks that will determine a successful integration:

a) Perform communication and data checks.

b) Successfully execute command set.

c) Monitor system to ensure proper operation via real time data stream of sensor readings, system voltages, and ambient temperature.

I. List any additional LSU personnel support needed for a successful integration other than directly related to the HASP integration (i.e. lifting, moving equipment, hotel information/arrangements, any special delivery needs...):

N/A

J. List any LSU supplied equipment that may be needed for a successful integration:

We will carry all our required equipment and tools. We may need standard set of wrenches, soldering station, oscilloscope, and heat gun.