



# **HASP – Student Payload Interface Manual**

## I. Introduction

This document describes the basic features of your HASP payload mounting plate and provides information on the mechanical, electrical, power, and data interfaces. Further, the expected interface requirements for your payload are specified on the attached “HASP Student Payload Summary” sheet. Please take note that your payload must conform to HASP interface standards and not exceed the specified payload requirements. Any identified issues will need to be resolved by you prior to integration. Any anticipated change in your HASP interface requirements must be approved by HASP Management prior to your integration delivery date. Questions on the HASP interface standards or to request approval of an interface requirement change should be directed to Dr. T. Gregory Guzik at [guzik@phunds.phys.lsu.edu](mailto:guzik@phunds.phys.lsu.edu).

## II. HASP - Student Payload Mechanical Interface

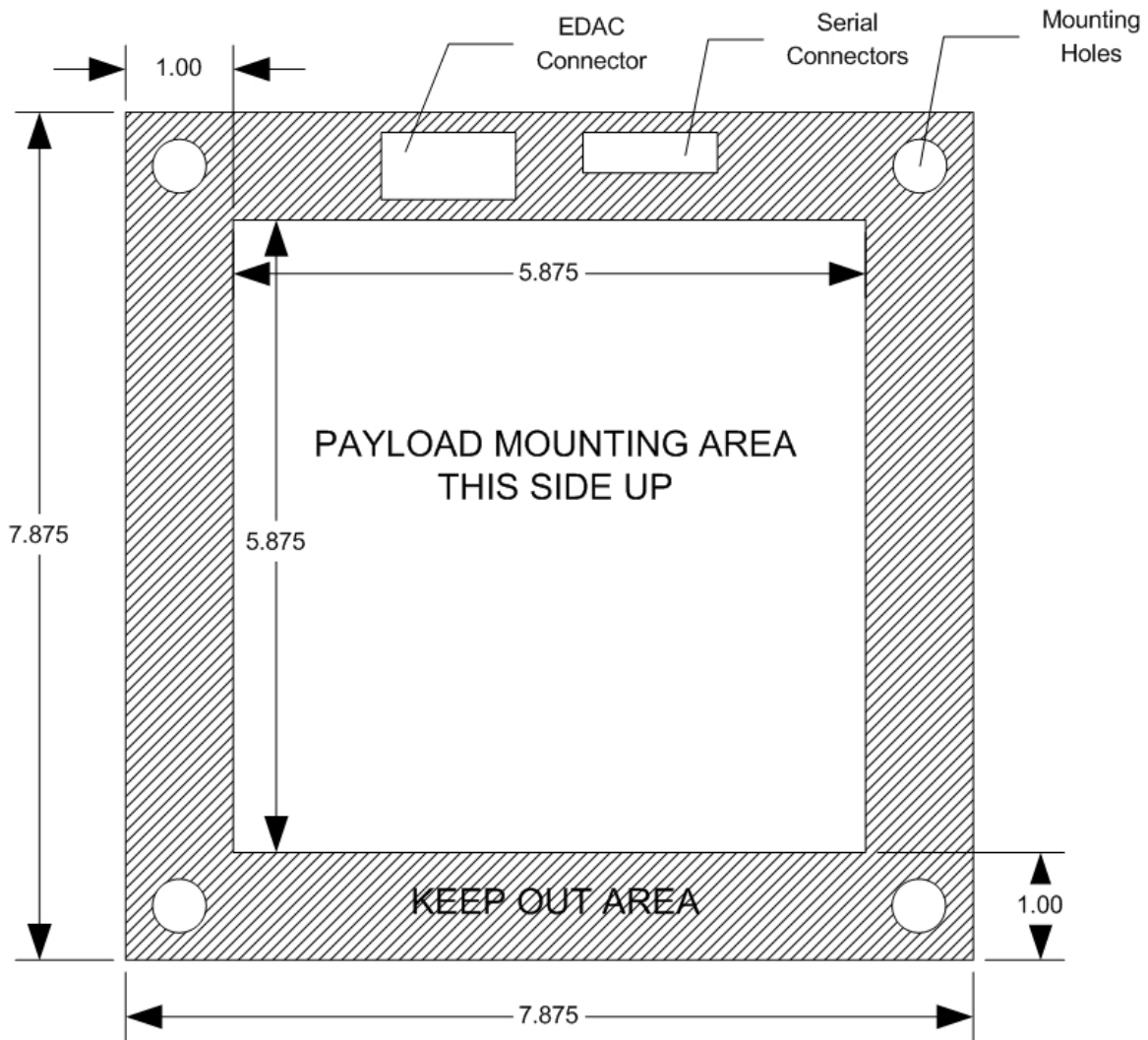
Included in this mailing is the HASP mechanical interface mounting plate for your payload. You will need to attach your payload to this plate avoiding the “forbidden” areas and conforming to the size and weight restrictions associated with your payload class. In addition, **the payload must be secured so that it remains intact and attached to the mounting plate under a 10 g vertical and 5 g horizontal shock.** It is advised that appropriate analyses and/or test data be collected to provide evidence that your payload and mounting will satisfy this requirement.

The mechanical interface mounting plate is composed of ¼” thick PVC and diagrams of the plates are attached here as Figure 1 for the small payloads and Figure 2 for the large payloads. Each mounting plate has restricted, “forbidden” areas usually confined to the plate edges where the electrical connectors are located and where the plate is bolted to the HASP frame structure. Intrusion by the payload into these areas is constrained as indicated in the figures, but outside of these areas the plate can be modified for payload support structure and, if needed, downward pointing apertures. [Note that located immediately below each large payload (i.e. a ¼” clearance) will be the HASP thermal and EM insulation plates, so downward pointing apertures for these payloads would not be appropriate.] The general “allowed” region is marked on your mounting plate as well as the plate side that will be up. All components attached to the mounting plate by the student team (e.g. payload, support structure, bolts, DC converters, antennas, etc) must be included in the weight budget and total less than the maximum allowed for the payload class.

The constraints on payload mass, footprint and height are listed in Table 1. Note that these constraints are maximums that your payload should not exceed. The mass constraint excludes the mass of the payload mounting plate but includes your mounting hardware. During integration your payload will be weighed and measured to determine conformity with the constraints. In addition, we will assess your shock test data and/or analysis. Any issues identified during this process will need to be resolved by the student group prior to integration with HASP.

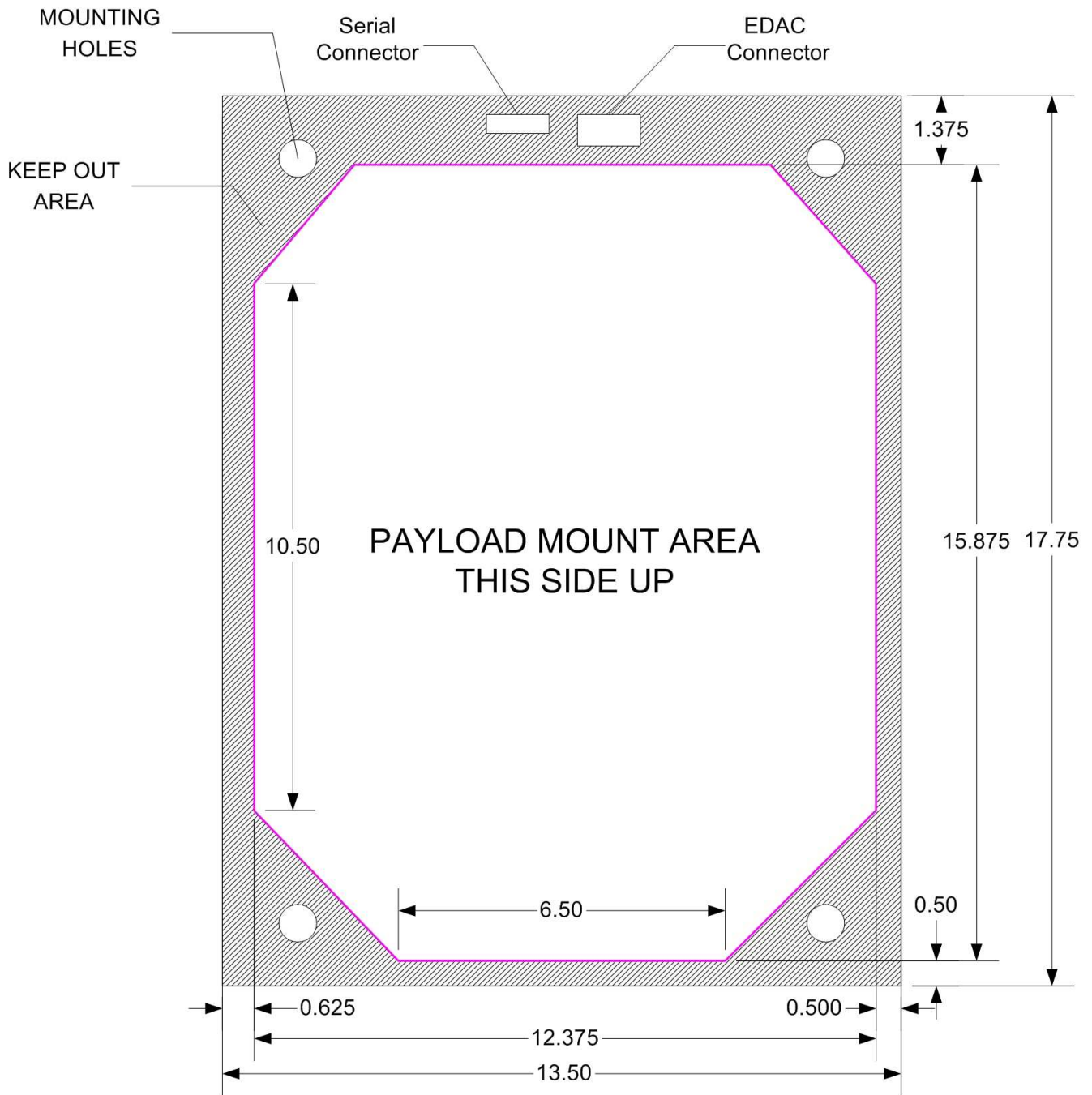
**Table 1: Mechanical Constraints on HASP Student Payloads**

Class	Mass	Footprint	Height
Small	3 kg	15 cm x 15 cm	30 cm
Large	20 kg	38 cm x 30 cm	30 cm

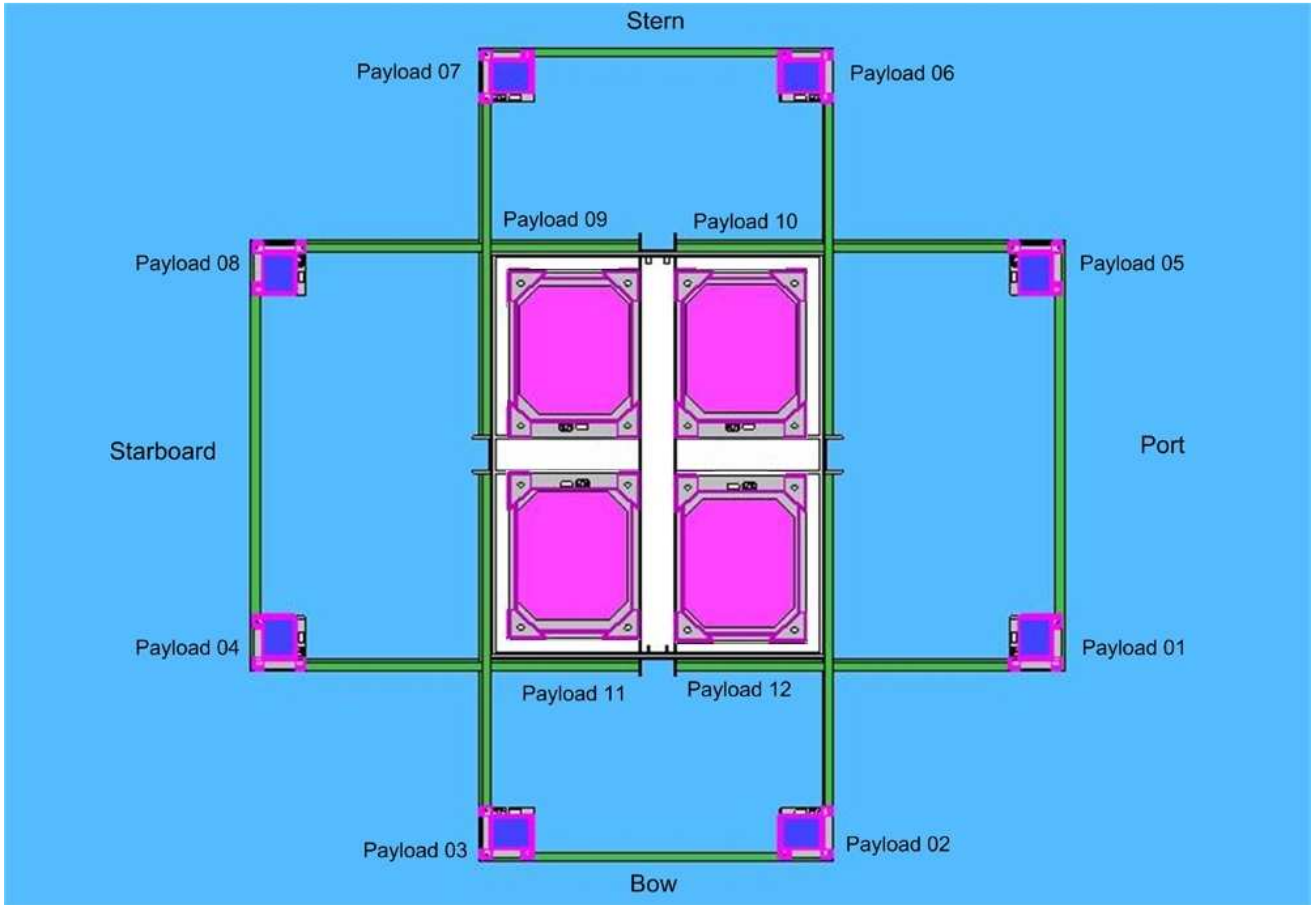


**Figure 1:** Small student payload mechanical interface plate

Your payload plate is keyed to a particular position on HASP. Your position number is given as the “Payload ID Number” on the Payload Summary sheet and the standard HASP positions are shown in Figure 3. On the figure, “bow” and “stern” refer to sides that are closest and farthest from the launch vehicle prior to launch. During flight, however, any side can be located toward or away from the sun or flight path as there is no orientation control on HASP. In addition, to identifying your physical location on HASP the ID number is also used to tag your downlinked telemetry stream as well as to route uplinked commands to your payload.



**Figure 2:** Large student payload mechanical interface plate



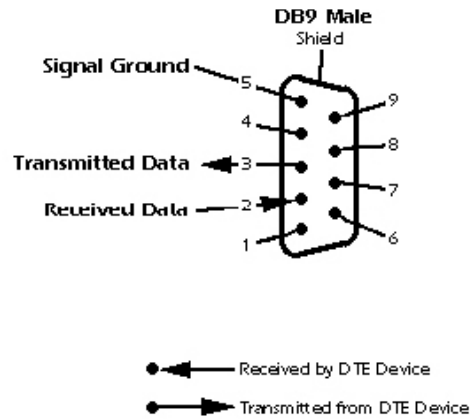
**Figure 3:** Top down view of the HASP student payload positions

### III. HASP – Student Payload Mounting Plate Connectors

Your payload mounting plate includes two connectors. A DB9 for serial up and down link and a EDAC 516-020 for power, discrete commands and analog output. Both connectors already include a 24” wire pigtail from the topside of the mounting plate. These pigtails can be fitted with your own connectors or wired directly to internal components of your payload. HASP will interface to both of these connectors on the bottom of the plate using a corresponding plug.

#### A. Serial Connector

Student payloads will send data to and receive commands from the HASP flight system via a single RS-232 serial connection using **8 data bits, no parity, 1 stop bit and no flow control**. The serial port speeds will be 1200 baud for the small payloads and 4800 baud for the large payloads. The serial connection will be a DB9 DTE (Data Terminal Equipment) device connector. Only the transmitted data, received data, and signal ground wires will be used. Figure 4 shows the pin layout of the DB9 connector with the pins used for the HASP serial interface labeled.



**Figure 4:** DB9 pins used for the HASP serial interface

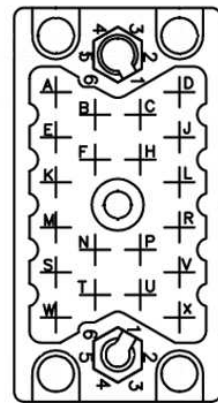
As the student payload will be a DTE device, you will need to wire the DB9 pigtail as a NULL modem to your payload (i.e. pin 3 to your receive, pin 2 to your transmit). This HASP serial connection is mounted on the student payload base plate that is provided to you.

#### B. The EDAC 516 Connector

A twenty pin EDAC 516 (manufacture number 516-020-000-301) will be used to interface with HASP system power, analog downlink channels and discrete commands. A diagram of the EDAC receptacle is shown in Figure 4. Pins are labeled A through X and functional assignments are listed in Table 2 as well as described in the following sections. The wires from the connector are color coded according to function as listed in Table 2. Note that the signal return (pins L,R) is used for both the analog and discrete channels and should not be confused with the power ground (pins W,T,U,X).

**Table 2:** Pin Layout of EDAC 516-020

Function	EDAC Pins	Wire Color
+30 VDC	A,B,C,D	White with red stripe
Power Ground	W,T,U,X	White with black stripe
Analog 1	K	Blue
Analog 2	M	Red
Signal Return	L, R	Black
Discrete 1	F	Brown
Discrete 2	N	Green
Discrete 3	H	Large Only – Not wired
Discrete 4	P	Large Only – Not wired



**Figure 5:** The EDAC 516-020 receptacle pin layout.

#### **IV. HASP – Student Payload Power Interface**

Power is provided through the EDAC 516 on pins A, B, C, and D for the +30 VDC and pins W,T,U, and X for the ground. The multiple pins are used to supply the available current from the HASP system in parallel. Thus, you will likely want to connect all wires to the appropriate power input terminal in your payload. **Note that power is fused for a maximum current draw of 0.5 amps for a small class payload, and 2.5 amps for a large class payload.** You will need to assure that these current limits are not exceeded during payload operation. On power-up any transient that exceeds 1.5 amps (small class) or 6.0 amps (large class) for one (1) second will open the fuse. It will be the responsibility of the payload to convert internally the +30 VDC to whatever voltages are required.

**WARNING:** Use of the wrong EDAC connections for power (+30 VDC as well as ground) will have undesirable consequences including a non-functional payload or a possible blown power circuit on HASP. It is therefore imperative that you assure that only pins A,B,C,D are wired to your payload as +30 VDC power supply and pins W,T,U,X are wired to your payload as power ground!

**NOTE:** Even though the power bus is referred to as delivering +30 VDC, the actually voltage provided by the batteries during the flight is closer to 32 V to 33 V during the start of the mission and remains steady until the last several hours of the flight when the voltage may drop to 29 V to 30 V. Thus, your payload must be designed to handle input voltage in the range 29 VDC to 33 VDC.

#### **V. HASP – Student Payload Analog Download Interface**

Two 0 to 5 VDC analog channels will be accessible through the EDAC 516 connector. These channels are sampled once a minute, digitized and transmitted by the ballooncraft systems to provide real-time monitoring of two key payload parameters (e.g. temperature). Pins K & L will be analog channel one (K: Signal, L: Return) and pins M & R are for analog channel two (M: Signal, R: Return).

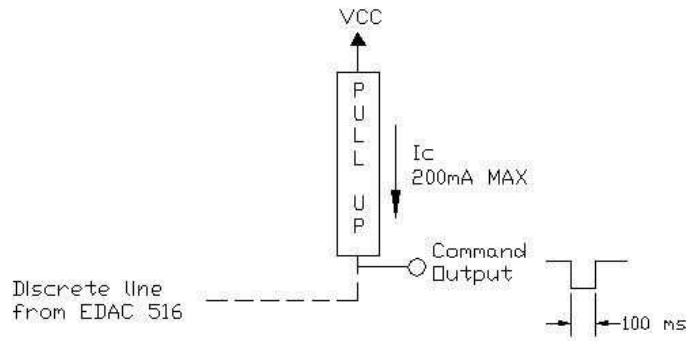
#### **VI. HASP – Student Payload Discrete Command Interface**

Discrete commands are hardware lines that are used to change the payload state in some fashion and, during flight, are issued verbally to the HASP operator. Generally, discrete commands come in pairs, one to do the state change and one to reverse the change, and are not used as a toggle. For example, each student payload will have two discrete commands assigned to it. One of these commands will turn the +28 VDC power on and the other will turn the power off. These power commands switch relays internal to the HASP control system and are not directly available to the student payload. However, depending upon your payload position on HASP (Figure 3), the EDAC 516 connector may have extra pins assigned for discrete commands that can be used internal to your payload. Small payloads 1,2 and 5 will have two discrete lines and large payloads 9, 10, 11 and 12 will have four pins assigned to discrete command signals. All other small payloads (3, 4, 6, 7, and 8) have no extra discrete lines available. As shown in Table 1, discrete 1 is on pin F (brown wire) and discrete 2 is on pin N (green wire). For large payloads, discrete 3 is on pin H and discrete 4 is on pin P. Note that the student payload

mounting plate wiring pigtail does not include connections to pins H or P. You can, however, wire to these pins if the extra discrete commands are needed.

The discrete signals are provided as open-collector command outputs that can sink a maximum of 200 mA at a maximum of 50 volts. The output of the open-collector is pulled low for 100 milli-seconds when a command is sent. The discrete signals can be used as inputs

to logic circuitry with an appropriate user supplied VCC voltage and pull-up resistor or directly to energize latching relay coils provided the maximum sink current does not exceed 200 mA. An example interface circuit for the discrete signals is shown in Figure 5.



**Figure 6:** Conditioning circuit for discrete command line interface.

## VII. HASP – Student Payload Serial Communication

This section describes the serial data downlink communication and uplink serial commanding between the student payloads and the HASP flight computers. Also described is the command record format, how data on the ground is retrieved by the student payload groups and in minor detail, how the HASP flight system will handle student payload data.

### A. Data Downlink

There is **no required data format** that the student payloads will have to adhere to when sending data to the HASP serial I/O process. The student payload will merely transmit data over the serial link as a “stream” and the HASP serial I/O process will package these data into records of appropriate size. The data are accepted by the HASP system at the rate of 1200 baud for small class payloads and 4800 baud for large class payloads. Record size will be based upon the student payload data rate so that new data will be available on the ground every 5 to 10 minutes. Each student payload’s record size will be independent from one another and will be set during payload integration.

Once on the ground, data will be written to files named according to the student payload identification number from which it came and the day, hour, minute and second on which the file was opened. The data is written to these files as it was received

**Table 3:** Suggested Student Payload Data Format

Byte	Bits	Description
1	0-7	Record Type Indicator
2-5	0-31	Timestamp (seconds since January 1, 1970)
6-9	0-31	Timestamp (nanoseconds past the last second)
10-11	0-15	Record Size
12	0-7	Least significant 8 bits of the record checksum
13-n		Data

from the student payload. An open file will be closed and a new file will be opened each time one hundred records have been written to the current open file. These data files will be available, in near real time, on the HASP website under the “Flight Information” page (<http://laspace.lsu.edu/hasp/Flightinfo.html>). Using a standard web browser students will be able to download the latest payload files to their home institutions as well as have access to other

HASP flight information including environmental (temperature) data, NMEA (GPS) data strings, other HASP status information and payload tracking through Google Maps.

While we do not require your data to follow any particular format we do have several recommendations that will likely reduce some of your post-flight data analysis problems. First, uncontrollable effects that occur during data transmission to ground can result in bit loss or other forms of corruption. Therefore, it is recommended that you do implement some type of record format that includes a checksum, timestamp or record counter and other housekeeping information. An example of such a format, that is similar to what we use in our professional balloon payloads, is shown in Table 3. Such a format will allow you to keep track of your records and allow you to identify corrupted data that should be removed from further analysis. Second, if you are not anticipating using the serial stream at the full rate you should consider transmitting multiple copies of the same record. This would provide you with a backup in case a record is corrupted. Third, know the size of your records. This will enable us to make the size of the HASP records that are transmitted to the ground such that your payload record will not be broken across files.

### B. Serial Command Uplink

In addition to discrete commands, student payloads will have the opportunity to uplink 2 byte commands over the serial link to the payload. These serial commands provide flexibility in experiment control during flight. As is done with discrete commands, serial commands will be issued to the HASP operator for uplink to HASP during operations. Each student payload will be assigned a payload identification number, which will direct the command to the proper payload. This **Payload ID Number** is listed on your HASP Student Payload Summary sheet.

To request a command uplink you will need to provide the HASP operator with your payload ID number and the two bytes, in hexadecimal format, that you wish to be transmitted. The two bytes of your command will not be processed by the operator or the HASP systems, but will be transmitted as is to your payload. Therefore, it is the responsibility of the student group to assure the validity of the payload ID and contents of the two command bytes given to the HASP operator for transmission. To avoid miscommunication it is highly recommended that you submit your command to the operator in writing.

Once your command is transmitted and received onboard the ballooncraft, HASP will format and route a command string to your payload over the serial link. Each command string will include 7 bytes and the format of this string is shown in Table 4. Note that the payload command bytes are included as bytes 3 and 4 in this string. After reading the string you should validate the format, extract your command byte and process the command. [You may also find it useful to include in your downlink data record a section devoted to the last command received

**Table 4:** Format of HASP Command String Sent to Student Payload

Byte	Hex Value	Description
1	1	Start of Heading (SOH)
2	2	Start of Text (STX)
3	command byte 1	First byte of the command transmitted from the ground
4	command byte 2	Second byte of the command transmitted from the ground
5	3	End of Text (ETX)
6	D	Carriage Return (CR)
7	A	Line Feed (LF)

and its current status. This will provide you with the ability to determine if your commands have been received and executed by your payload.]

The HASP operator will transmit commands for a limited time each hour. Each command takes about 1 minute to execute and to receive the command response. Student payload groups will submit commands to the HASP operator in a round robin fashion. There could be as many as 12 student groups that need to issue commands and, thus, there could be a 12-minute delay between commands directed to your payload. Therefore, it is highly recommended that you design your instrument so that it doesn't need to be constantly commanded.

Further, it is possible that a command may be improperly routed or corrupted during uplink and it is the responsibility of the student payload to identify and validate the received commands. We, therefore, recommended that you implement some type of checksum and identification bit string that will uniquely identify commands that you receive from the HASP flight system. An example format is shown in Table 5 where several bits are reserved for a checksum and your

payload ID number. This format still allows you one byte or 256 unique commands.

**Table 5: Suggested Student Payload Command Format**

Byte	Bits	Description
1	0-3	Least significant 4 bits of the command checksum
1	4-7	Student Payload ID
2	0-7	The command – 8 bits allows for 256 unique commands

### VIII. Other Recommended Documentation

Listed here are several documents that we highly recommended you download and review. These documents will provide background on professional balloon flight procedures, requirements that you may need to satisfy and information on flying with HASP.

**HASP Web Site:** The HASP website at <http://laspace.lsu.edu/hasp> includes documents, presentations, news items, application materials, as well as summaries of previous student payloads and information about HASP flights. This site always has the most current version of this document as well as templates for the deliverables discussed in the next section.

**Balloon Flight Application Procedures User Handbook** is available from the Columbia Scientific Balloon Facility website under Conventional Flight Documentation <http://www.csbf.nasa.gov/convdocs.html> This document provides background on professional balloon flight procedures and requirements.

**Recommendation for Gondola Design** plus associated certification, safety plan and structural requirements documents are available from the Columbia Scientific Balloon Facility website under Gondola Design Documentation <http://www.csbf.nasa.gov/gondoladocs.html> These documents provide background on the kinds of mechanical certifications and requirements that you might be required to satisfy particularly in regard to pressure vessels, safety and structural integrity.

**Development of the High Altitude Student Platform** is available from the HASP website under Presentations <http://laspace.lsu.edu/hasp/Presentations.html> This paper provides details of the first HASP flight in September 2006 including information on the flight profile and temperature environment.

**First Flight of HASP** is a PowerPoint presentation available from the HASP website under Presentations <http://laspace.lsu.edu/hasp/Presentations.html> that provides pictures on the Ft. Sumner location as well as HASP flight and recovery operations.

## **IX. Deliverables**

Your seat on the next HASP flight is contingent on providing documentation describing your payload as well as your plans for integration and flight. In addition, application for a future HASP flight will be contingent on delivery of a Final Flight / Science Report. These documents are described below and templates are available on the HASP website.

**Payload Specification & Integration Plan:** This document provides technical details on the final flight configuration of your payload including measured weight, measured current draw (@30 VDC), downlink data format and rate, uplink commands, analog output usage, discrete command usage, and dimensioned mechanical drawings. In addition, your plans for integration with HASP should be detailed including, at least, all test procedures and test procedure validation results, requested test equipment, schedule and personnel participating in integration.

**Payload Integration Certification:** At integration all interfaces will be documented and validated, correct operation of the payload will be verified and any issues identified will be detailed. This certification will be handled by HASP management during integration. Note that you will not be able to fly until this certification is complete.

**Flight Operation Plan:** This document will detail procedures for flightline setup, pre-launch checkout, flight operations, error recovery, safeing and payload recovery including a timeline showing specific events relative to launch at  $T=0$  and identifying personnel participating in flight operations. Note that any operations requested to be performed by HASP flight personnel other than power-up ~one hour prior to launch ( $T - 1$  hr) and power down prior to terminate must be specified in this document.

**Final Flight / Science Report:** A final report on the results from the flight of your payload is due by the end of the calendar year. This report should include an assessment of the payload performance, problems encountered, lessons learned as well as the science / technical results from the flight.